



TOYO-AC

Air Condition Co. LTD

VRV SYSTEM



WORLD'S FAMILY, COMFORT QUALITY

TOYO-AC Air Condition (JAPAN):
Add: 1080-2, Full, Mibu Machi, Shimotsuga Gun, Tochigiken 321 0221, JAPAN
Tel: (+81) 2 8228 6644 Fax: (+81) 2 8228 6645
Web Site: www.toyo-ac.com

TOYO-AC Air Condition (China)
Add: No.13788, Century Avenue, Lixia district, Jinan City, Shandong Province, P.R.China.
Tel: +86-531-88901036
Website: www.toyo-ac.com.cn

- R410a
- Continues Heat & Cool
- DC Inverter
- Benefit For Users
- Benefit For Installers
- The Total Pipe Length 1000m
- 2-72Hp Outdoor Unit
- Fast Installation

TOYO-AC
2019
Catalogue



Product Lineup

Outdoor Unit (All DC Inverter)

(kW)	25.2	28.0	33.5	40.0	45.0	50.4	56.0	61.5	Page
(HP)	8	10	12	14	16	18	20	22	
	▲	▲	▲	▲	▲	▲	▲	▲	3

8/10/12HP

14/16/18/20/22HP

24/26/28/30/32/34/36/38/40/42/44HP



46/48/50/52/54/56/58/60/62/64/66HP

68/70/72/74/76/78/80/82/84/86/88HP



VRV Individual Series

(kW)	61.5	67	73	78.5	85	90	Page
(HP)	22	24	26	28	30	32	
	▲	▲	▲	▲	▲	▲	24

Mini VRV Series

(kW)	8.0	10.0	12.3	14.0	16.0	22.4	26.0	Page
50Hz/60Hz	▲	▲	▲	▲	▲			25
50Hz						▲	▲	25

Product Lineup

Indoor Unit (DC fan motors)

Capacity(kW)	Appearance	2.2	2.8	3.6	4.5	5.6	7.1	8.0	9.0	10.0	11.2	12.5	14.0	15.0	Page
Four-way Cassette			▲	▲	▲	▲	▲	▲	▲	▲	▲	▲	▲		31
Slim Duct		▲	▲	▲	▲	▲	▲								49
Mid ESP Duct					▲	▲	▲	▲	▲	▲	▲	▲	▲		51
Wall-mounted		▲	▲	▲	▲	▲	▲								57

Indoor Unit (AC fan motors)

Capacity(kW)	Appearance	2.2	2.8	3.6	4.5	5.6	7.1	8.0	9.0	10.0	11.2	12.5	14.0	15.0	Page
One-way Cassette		▲	▲	▲	▲	▲	▲								35
Two-way Cassette		▲	▲	▲	▲	▲	▲								39
Four-way Cassette							▲	▲	▲	▲	▲	▲	▲		31
Slim Duct		▲	▲	▲	▲	▲	▲								49
Mid ESP Duct					▲	▲	▲	▲	▲	▲	▲	▲	▲	▲	51
High ESP Duct											▲	▲	▲	▲	53
Ceiling&Floor					▲	▲	▲	▲	▲	▲	▲	▲	▲		59
Wall-mounted		▲	▲	▲	▲	▲	▲								57

Capacity(kW)	Appearance	22.0	28.0	45.0	56.0	Page
High ESP Duct		▲	▲	▲	▲	53
Fresh Air Processor		▲	▲	▲	▲	55

Heat Recovery Ventilator

Air Volume(m³/h)	Appearance	200	300	400	500	600	800	1000	1500	2000	2500	3000	4000	5000	Page
		▲	▲	▲	▲	▲	▲	▲	▲	▲	▲	▲	▲	▲	65



Adopt air conditioning solutions from a trusted brand

At Toyo-ac, our focus is on providing smart solutions for better business and a higher quality of life. We imagine all sorts of innovative ways to improve how homes and businesses function and to help them run smoothly.

We're proud to say our Toyo-ac brand is recognized as one of the world's leading intuitive product design companies, and one of the world's top electronics producers.

As such, Toyo-ac system air conditioners are held in high esteem around the world and have been selected for a multitude of applications, including shopping centers, airports, stadiums and hotels. And in constant pursuit of excellence, we continue to invest heavily in research and development, performance testing and quality control to deliver superior air conditioning systems to market.

Control the atmosphere with smart, efficient technology

Toyo-ac system air conditioners provide the best in performance and efficiency to ensure residential and commercial environments are perfectly tempered, healthy and comfortable - all while conserving costs. Our intelligent, high-capacity air conditioning systems offer just the right solution for application any application.

Energy-efficient, eco-friendly technology

Toyo-ac is committed to providing eco-friendly air conditioners and air solutions that help prevent global warming and contribute to resolving energy shortages. Using components such as eco-friendly R-410A refrigerant and smart inverter technology, TOYO air conditioners reduce air pollution and provide comfortable cooling with minimal power consumption, saving the environment and costs.

Reliable performance

Reliability is a key factor when choosing an air conditioning system. With their robust design, Toyo-ac system air conditioners offer the strength and reliability to ensure consistent performance at all times. Their perfectly synchronized parts offer balanced operation for improved durability and longevity. Furthermore, weather resistance keeps the units operating even in adverse temperatures.

Exceptional design and innovation

Toyo-ac system air conditioners are lauded industry wide for their innovative technology and exquisitely beautiful, yet high-functioning design. From prestigious institutions and exhibitions across the globe, TOYO units have garnered copious awards, including the Galeria de Innovacion Award, iF Product Design Award, Comfort & Design Award, and Good Design Award.

Nomenclature

Indoor Unit

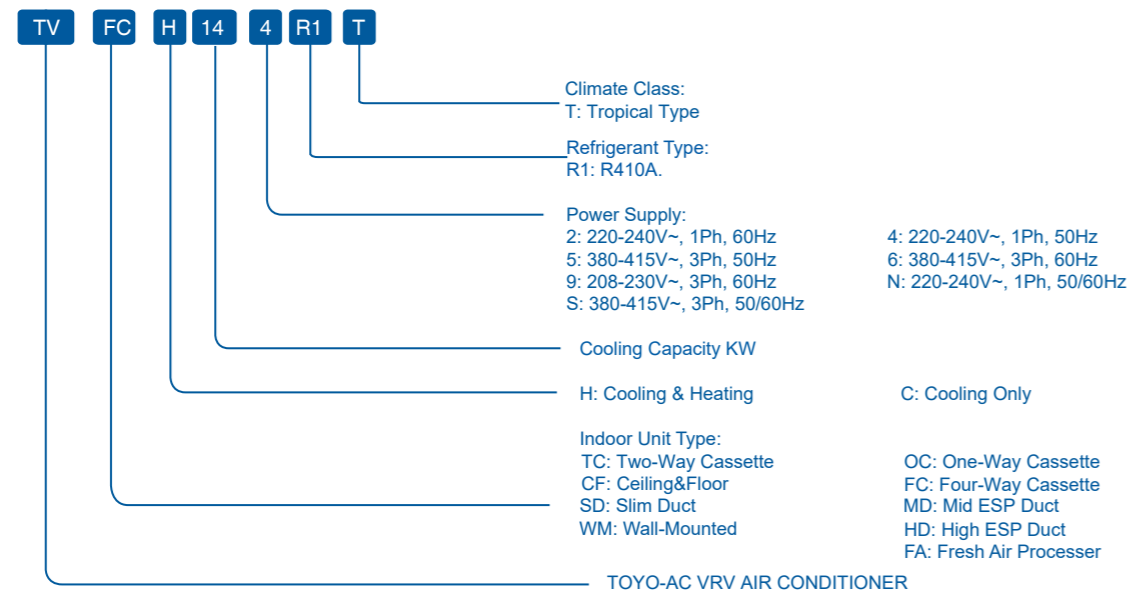

Outdoor Unit

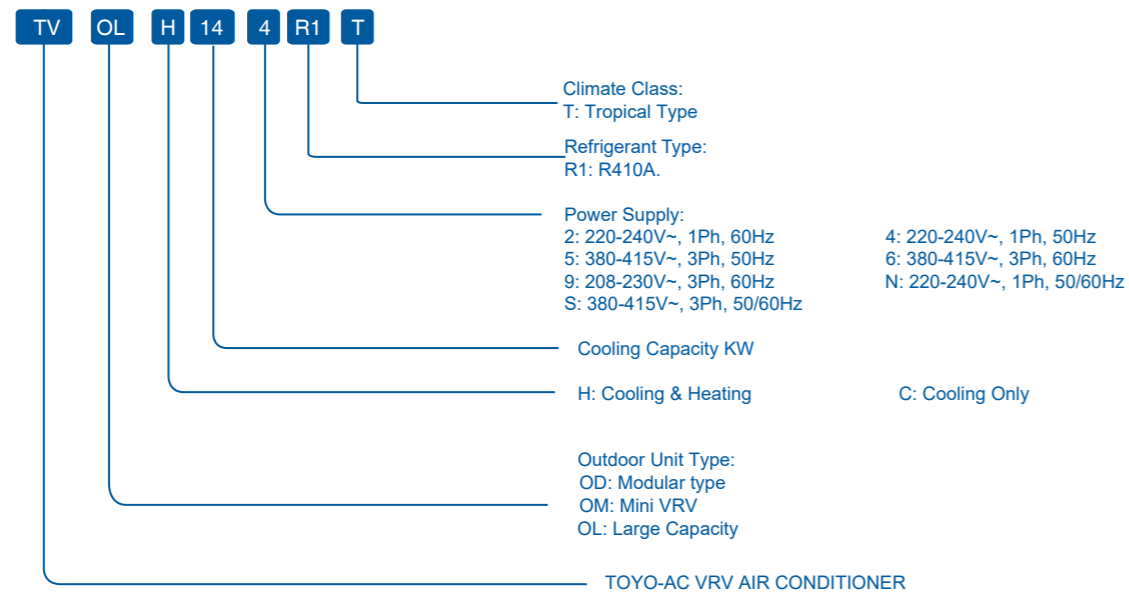

Why choose TOYO-AC ?

A history of industry-leading product innovation

Becoming a global leader in any industry takes more than just time. For over 90 years TOYO-AC has shown that it takes industry-leading product innovation and a commitment to excellence in order to climb to the top. This commitment led TOYO-AC to develop the first Variable Refrigerant Volume (VRV) system in 1982 and to become a pioneer with our Variable Refrigerant Volume systems.

TOYO-AC's 3 core technologies

TOYO-AC is an industry-leading HVAC technology company. We develop state-of-the-art technology that provides indoor comfort solutions for our customers. We do this by focusing on 3 core technologies. Our refrigerant control technology provides an efficient and effective way to transport heat. Daikin inverter technology allows us to maximize energy efficiency and heat pump technology provides an effective method for moving refrigerant.

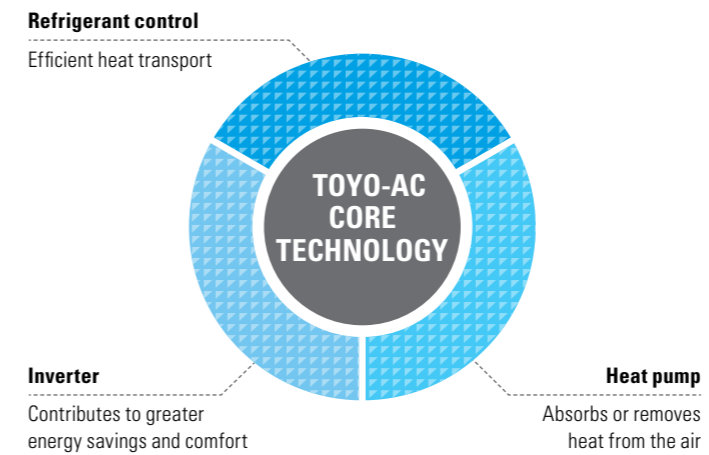

The total solution

TOYO-AC's products and controls are designed to provide a flexible, scalable, total indoor comfort solution. We are committed to supporting our customers at every phase of the project to ensure that the highest quality and most cost effective solution is the one that is provided. From project conception throughout the life of an HVAC system, TOYO-AC provides world class products and support. A single source and total solution for your HVAC requirements.



Why choose TOYO-AC VRV?

Unique products that make the difference

In efficiency

- Variable Refrigerant Temperature technology leading to excellent energy efficiency
- Indoor units with advanced sensing technology and optional self-cleaning air filter panel

In comfort

- Variable Refrigerant Temperature technology preventing cold draughts
- 13 different indoor unit types and 77 models
- Low sound indoor and outdoor units

In aesthetics

- Stylish cassettes integrated in the ceiling
- Ceiling suspended cassettes
- Elegant wall mounted units

In installation

- Automatic refrigerant charge function
- Self-addressing control system after installation
- VRV Configurator for simplified and time saving commissioning
- Flexible connection possibilities for indoor and outdoor units

In control

- intelligent Touch Manager — a mini-BMS/ Centralized Controller that integrates all units in a cost-efficient system
- Easy integrating with third party BMS
- Dedicated control solutions for applications such as offices, shops, hotels, schools, etc.

In system design

- User friendly sizing and selection software
- CAD and Revit drawings
- Comprehensive engineering manuals

In after market support

- Nationwide field support organization
- 50+ product training facilities in the world
- Dedicated tech support team

In reliability

- Refrigerant-cooled electronics in outdoor unit
- Extensive testing before new units leave the factory
- Spare parts available
- ISO 9001 compliant manufacturing
- One of the best warranties in the industry
- Complete warranty details available from your distributor



Which VRV system offers the best solution?

Air cooled or water cooled?

Air cooled

- Fast and easy to install — no need for additional components
- Low maintenance costs
- Can be installed both outdoors and indoors
- Up to 88HP capacity for one system

Components:



Outdoor unit



Indoor unit

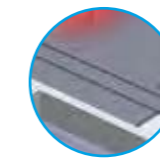

Refrigerant piping



Water cooled

- Suitable for multi-story and large buildings because of the almost unlimited possibilities of water piping
- Not affected by outdoor temperature/ climate conditions
- Reduce CO₂ emissions thanks to the possibility of geothermal energy as a renewable energy source

Components:



Condensing unit

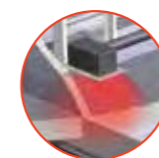

Indoor unit



Refrigerant piping



(Geothermal) water loop



Advanced performance & energy efficiency

Its advanced technology radically improves performance and reduces wasted energy. It includes a highly efficient Inverter Scroll Compressor, an innovative Hybrid heat exchanger and a large capacity diffuser.



Asymmetric Algebraic Scroll

applies a fluid, asymmetric algebraic scroll design that minimizes compression loss and maximizes performance during refrigerant compression. Compared with the involute, the scroll design is thickened toward the center, thus efficiency is higher.

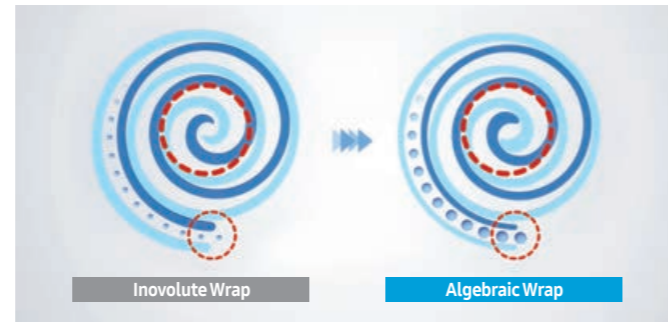

Improved winding wire

Featuring the world's largest 80cc/rev compressor, TOYO has developed the outdoor unit with.

The Largest Capacity Compressor

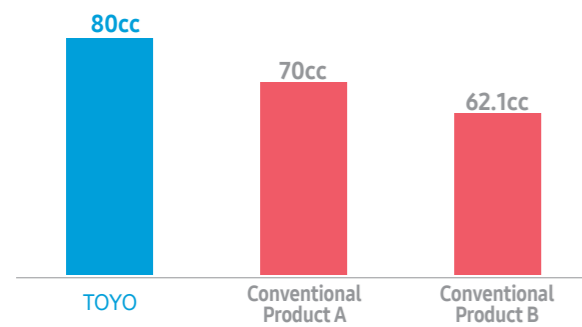

Instant shut off and gas leak protection

There's no need to worry about gas leaks or the accidental loss of refrigerant. A Gas Leak Operation System quickly detects and automatically takes the pump down a step and cuts off the refrigerant supply.

Enhance temperature control with more intelligent and efficient heating operation

With three improved key features, VRV ensures fresh airflow for increased comfort. Enhanced flash injection delivers reliable heating at lower temperatures, while more intelligent defrost and snow detection offer more precise operation, saving valuable energy and expenses.

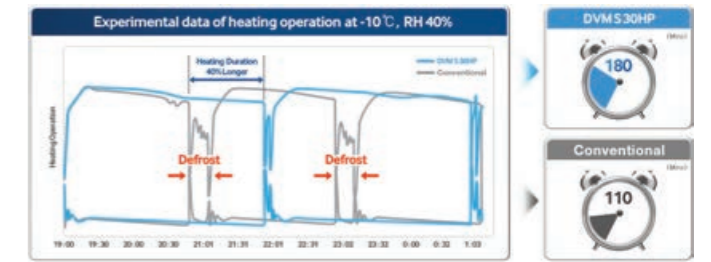

Auto snow blowing

Snow that accumulates and covers the outdoor units during the winter must be removed for units to operate properly. If the external temperature drops under 5°C, the auto snow-blowing function operates every 30 minutes, which might cause excess energy loss. But with the upgraded snow-detecting sensor, VRV can detect the amount of snowfall and operate the snow-blowing function only if snowfall is detected for 2 consecutive minutes. This improved detection prevents unnecessary operation for reduced energy consumption and costs.

EVI-Enhanced vapor injection

Heating condition, reducing the outlet temperature, increasing the compressor capacity, improving the heating performance.

Optimize the asymmetric vortex design

Heating condition, reducing the outlet temperature, increasing the compressor capacity, improving the heating performance.

Dynamic oil balance structure

Oil balance tube implementation parallel compressor and oil quantity dynamic equilibrium, ensuring the reliability of several paralleled compressors.

High efficiency motor configuration

Using high quality material concentrated stator, cooperate with neodymium magnet rotor, having outstanding efficiency.

High pressure cavity structure

Large exhaust buffer volume, reducing the air flow noise and vibration of the runtime.

Pressure relief valve structure

Improving the partial load efficiency, adapt to the transformer ratio working condition, improving the compressor performance.

The intermediate pressure servo mechanism

According to the operation pressure among dynamic adjusting middle pressure, has realized the axial flexible, optimization of dynamic vortex disk meshing, improve product performance.

High reliability of the bearing

Adopt cylinder bearing and self-aligning ball bearing bearing group, improving the reliability of the compressor.

Internal oil circulation structure

Lubricating oil to achieve internal circulation, reducing heat loss, decreasing the rate of spitting oil, improve the efficiency and reliability.

Positive displacement gear oil pump

Positive displacement gear oil pump to ensure the high and low frequency can satisfy the oil supply, improving the reliability of the compressor.

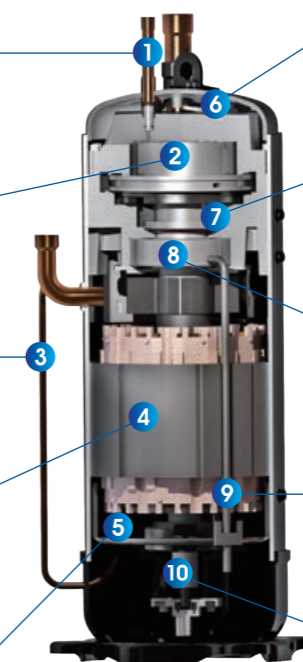

Maintain optimal comfort and control with energy- and cost-efficient technologies

Features several smart technologies that combined deliver world-class energy efficiency and economy with these technologies, boasts a superior 6 percent higher European Seasonal Energy Efficiency Ratio (ESEER) than conventional model. TOYO's innovation has not gone unnoticed. was recognized by Eurovent, an independent testing organization, for its world-first cooling and heating performance and efficiency.

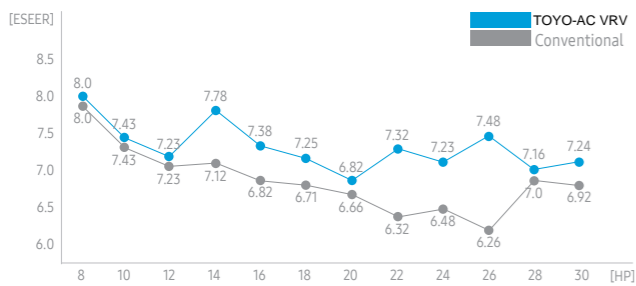

Reduce maintenance and energy costs with intercoolers

Features a PHE type intercooler, which improves cooling and heating efficiency by 30 percent compared to Shell & Tube and Double Tube type intercoolers. The higher heat exchange rate means optimal distribution, lowering maintenance and energy costs.

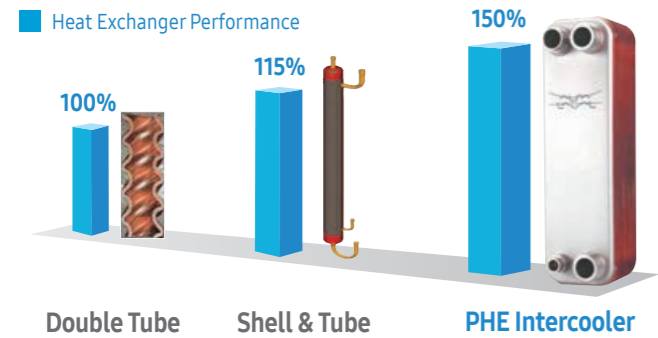

Limit power consumption with peak-demand control

To help businesses better manage power consumption and related costs, offers power-demand control for peak hours and seasons. This is especially useful when the electrical supply is insufficient or when businesses want to block excessive and wasteful energy usage.

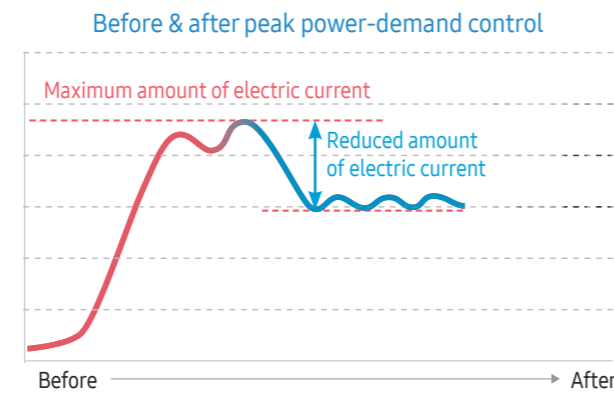

Prevent energy waste with quick cooling and heating

The third-generation innovative system, DDI, adopts a dual inverter compressor system. Both inverter compressors operate simultaneously, providing balanced oil distribution for quick cooling and heating and improved energy efficiency. Plus, the upgraded vapor injection system increases refrigerant flow by 20 percent compared to conventional products.

Reduce expenses with installation designed to be easy and flexible

The simplified yet powerful design of the unit eases the installation process. Non-polar communication between indoor and outdoor units promotes easier, safer wiring work, because the outdoor unit protects itself if the communication cable is mistakenly connected to a power terminal.

Lower setup costs with a smaller footprint and lighter weight

At 30 horsepower (HP), the large-unit capacity of facilitates economical installation with a smaller footprint and lighter weight—an ideal solution for larger buildings.

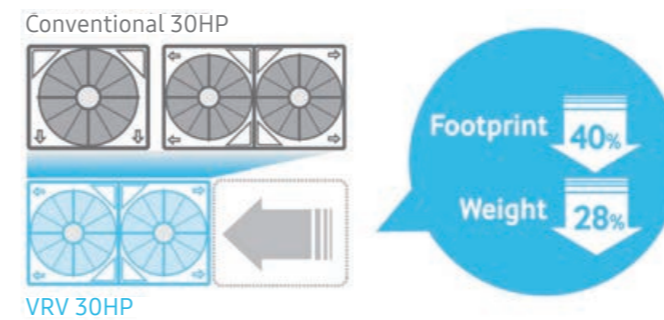

Optimized refrigerant distribution control

compensates for the long piping distance between outdoor units and indoor units by providing balanced refrigerant distribution. The individual indoor units perform capacity connection control and automatic refrigerant balancing to ensure balanced performance between the units.

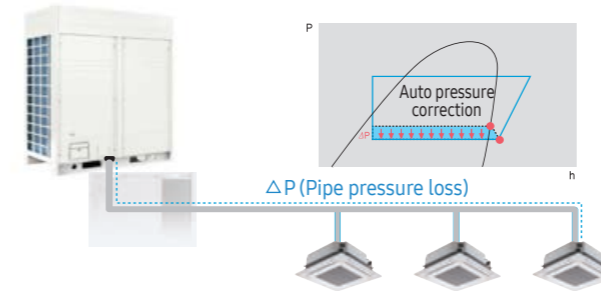

Install flexibly with extended pipe length and elevation

Provides extended piping length of up to 220 m (721.79 ft) and installation height of up to 110 m (360.89 ft), offering businesses more installation options. The piping distance is far between outdoor and indoor units, so individual indoor units perform capacity connection control and automatic refrigerant equalization for more balanced performance between units.

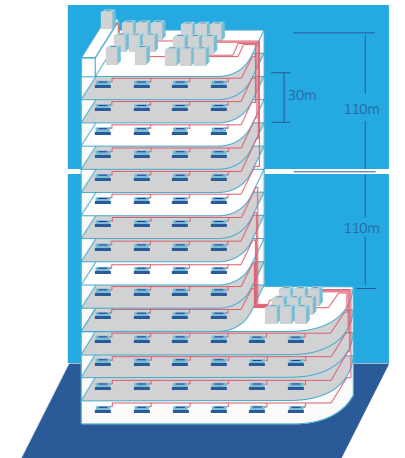

Refrigerant pump-down and pump-out

Provides refrigerant pump-down and pump-out functionality to simplify unit replacement, and ease additional installations and maintenance. When the outdoor unit requires maintenance, the refrigerant can recover into outdoor units and pipes. The refrigerant can also recover into outdoor units when moving indoor units or maintaining pipes.

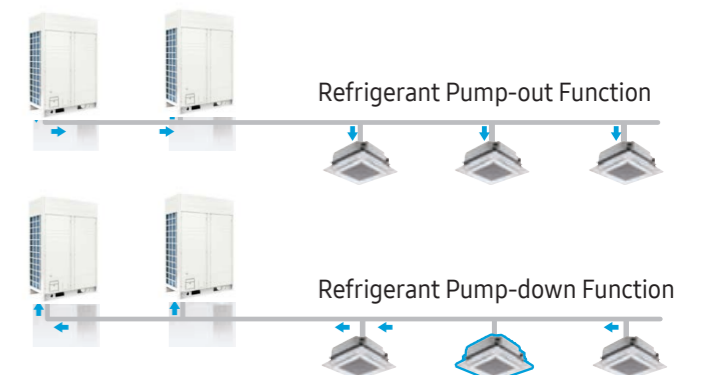

Make residents feel at home with an advanced operating system and flexible temperature control

is the best solution for residential buildings requiring a flexible, efficient and reliable air conditioning system. Smart Discharge Temperature Control enables operators to control the temperature without changing the outdoor unit's setting. Instead, each duct has an indoor discharge temperature control function to provide year-round comfort, whether in cooling or heating operation mode.

Lessen disruptions with 12-hour quiet operation

outdoor fans include an operation control system that drastically reduces noise levels. Quiet operation continues for 12 hours, so residents can relax and rest peacefully with less distraction during the night.

Minimize nighttime noise

A new Night Silent Control feature includes a timer and external contact interface module, which allow users to set the time they want to minimize noise. With the upgraded Night Silent Control feature, users can manage the noise control function when they want using the external controller.

Weather a wide range of outdoor temperatures comfortably. No matter how extreme the temperature, the high-performing can handle the condition—without the need for an additional unit. Featuring a wide temperature allowance, it can cool in heat of up to 48°C and provide warmth in the freezing cold of -25°C to ensure a constant and comfortable home environment.

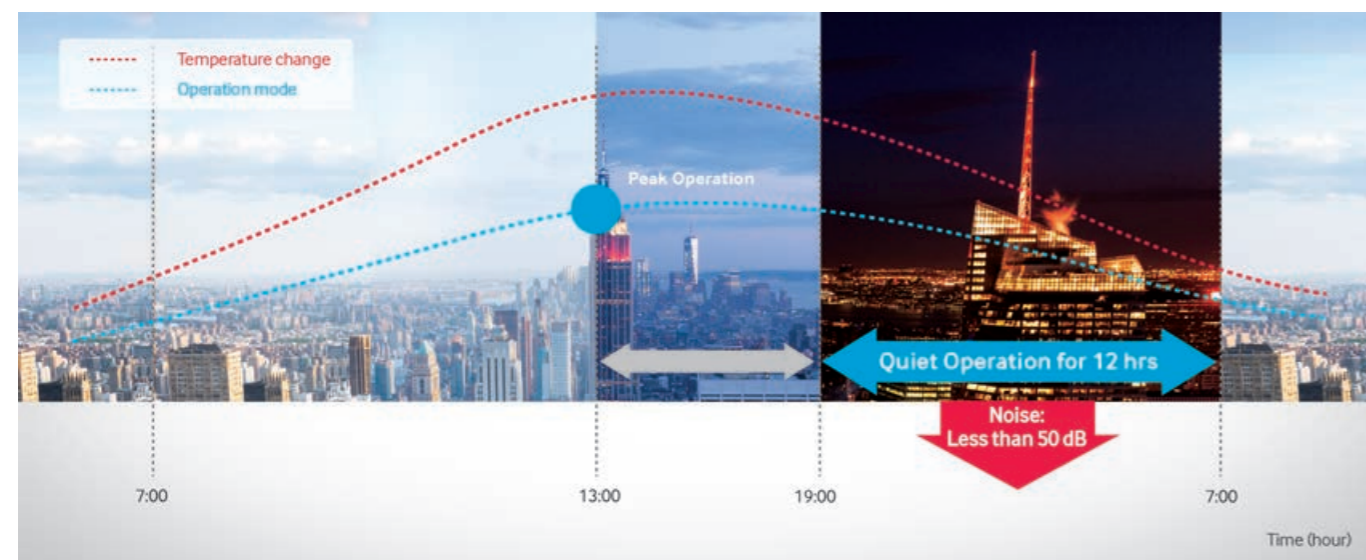
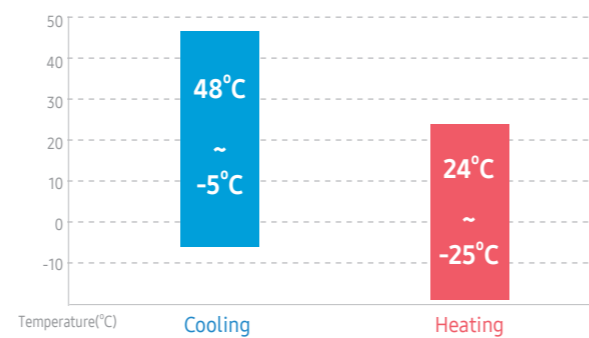

Monitor and resolve system issues remotely with a smart management system

features a smart, web-based management system for the ultimate in convenient management. The advanced system facilitates self-diagnosis, auto trial operations and mobile data transmissions, which users can easily access and monitor via the web-based tool.

System oversight from anywhere

With Wi-Fi S-Checker, users can access the system via their smartphones or tablet PCs to monitor operation status or data whenever and wherever. With self-diagnosis mode, VRV automatically monitors its operation status and displays an error code in response to signs of abnormal operation. Users can then identify and address the issue promptly.



Easy access

Thanks to the small opening on the outdoor unit, checking the outdoor status and setting option is easy, because users don't need to remove the entire front cover.

Automatic data backup

If a malfunction occurs, automatically backs up the last 30 minutes of operation data to ease the repair and recovery process.



Control your cooling anywhere

An optional Wi-Fi Kit lets you remotely control up to 16 indoor units using an App. Anytime and anywhere you can turn them on and off, select the operating mode and temperature, and utilize their other functions.



* Available on iPhones and Android devices. A Wi-Fi connection is required.

Stabilize operations with improved reliability and durability

Toyo-ac is dedicated to supporting comfortable living and working environments based on the strength of its technologies. With its robust design, delivers the reliability and durability that users need to ensure consistent performance at all times.

Extend compressor longevity with balanced operation

With conventional systems, one compressor operates longer than the other, which results in one compressor wearing down faster than the other. However, the system offers balanced compressor operation for improved durability and longevity and lower replacement costs.

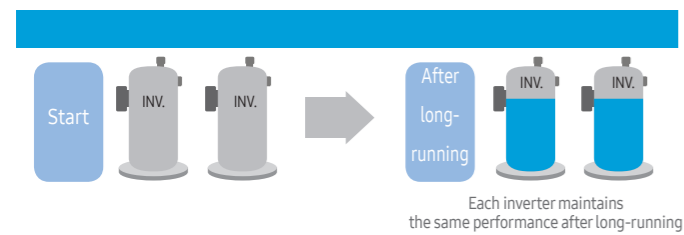

Refrigerant Cooling System

Refrigerant cooling system is not affected by the ambient temperature. Using refrigerant cooling system, VRV ensures better stability than conventional air cooling system.

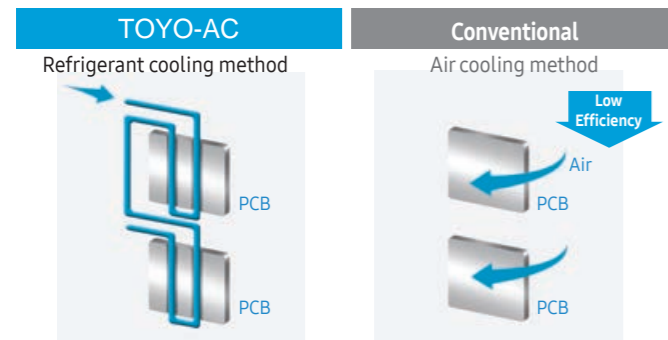

Protect your investment with corrosion and frost resistance includes a hydrophilic coating that facilitates efficient heat exchange and delays the onset of frost formation to provide consistent heating performance. An anti-corrosive coating also helps units to resist corrosion from the elements, with:

- Epoxy acrylic coating
- Acrylic and surfactant coating

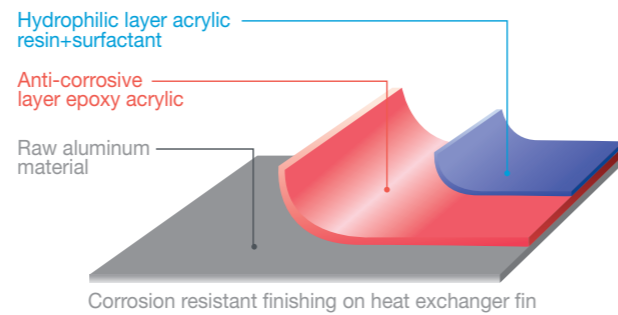

Rely on resilient performance with high oil storage capacity

With its large oil storage capacity and low Oil Circulation Ratio (OCR), can ensure reliable performance even for installations with long piping and high elevation.

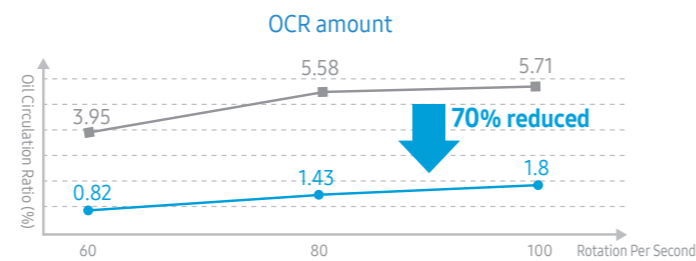

Control temperatures in extreme climates with reliable performance and efficiency

Desert is specially designed to tackle even the extreme temperatures typical of arid desert environments. Like the base unit, the Desert air conditioning system also features the innovative third-generation SSC technology. With its Dual Digital inverter, Desert offers unparalleled energy efficiency and industry-best cooling and heating performance. Perfect for large residential and commercial buildings, this air conditioning system provides continuous comfort for all variable environments.

The TOYO system air conditioner delivers optimal comfort, efficiency and performance with features such as:

- **Enlarged Capacity Desert.** Experience the ultimate heating and cooling capacity while optimizing space with an efficiently sized design.
- **Flexible installation.** Ease installation and reduce labor costs with a lightweight design and extended piping length and elevation support.
- **Year-round climate control.** Enjoy a comfortable environment even in extreme climates with advanced temperature control and rapid cooling and heating performance.
- **Smart management.** Monitor system performance effectively with convenient web-based data access and management from anywhere.
- **Reliable performance and durability.** Ensure dependable cooling and heating for all conditions with weather-proofing and corrosion resistance.
- **High energy efficiency.** Decrease energy consumption and costs with a dual inverter system featuring simultaneous compressor operation for higher performance.



Enhanced refrigerant cooling

Newly designed refrigerant cooling is unaffected by ambient temperature and can refrigerate stably even during partial load operation. Heat transfer efficiency is improved by 59 percent, with 65 percent less refrigerant pressure. The enhanced refrigerant cooling can operate efficiently under ambient conditions even with a bigger capacity of 26HP.

Economical installation with world largest capacity

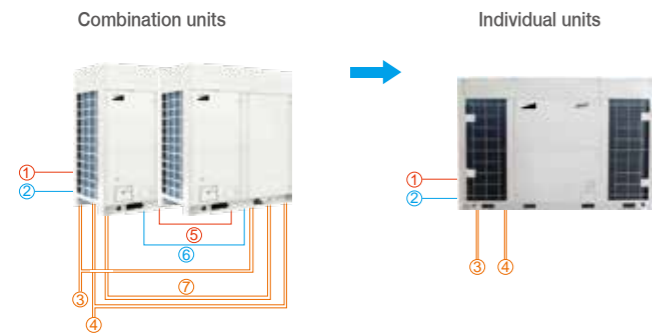

Hybrid heat exchanger

The heat exchanger offers a 49 percent larger heat transfer area, and a double layer that balances refrigerant flow. Refrigerant pressure drop is minimized by applying a different tube diameter in accordance with the refrigerant property.

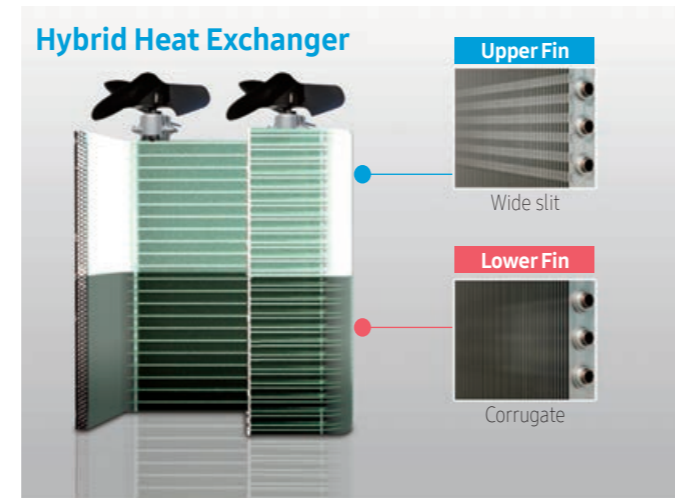

VRV 6 Series 380~415V-50/60Hz

HP			8	10	12	14
Model			TVODH(25)5R1	TVODH(28)5R1	TVODH(33)5R1	TVODH(40)5R1
Combination	HP		8	10	12	14
Capacity	Cooling	kW	25.2	28	33.5	40
	Heating	kW	25.2	28	33.5	40
Electric Data	Power supply	V~,Hz,Ph	380~415,3,50/60	380~415,3,50/60	380~415,3,50/60	380~415,3,50/60
	Cooling input	kW	5.31	6.11	8.48	9.90
	EER	W/W	4.75	4.58	3.95	4.04
	Heating input	kW	4.6	5.23	6.38	8.25
	COP	W/W	5.48	5.35	5.25	4.85
	SEER		6.7	6.5	7.2	6.5
	SCOP		4.2	4.0	4.2	4.3
Performance	Air Flow Volume	m ³ /h	12000	12000	12000	14000
	Sound Pressure level	dB(A)	≤58	≤58	≤58	≤61
Compressor	Type		DC inverter	DC inverter	DC inverter	DC inverter
	Quantity		1	1	1	1
Fan motor	Type		DC motor	DC motor	DC motor	DC motor
	Quantity		1	1	1	2
Max. No. of Indoor Units	unit		13	16	20	23
Connection Ratio	%		50~200	50~200	50~200	50~200
Dimension (WxDxH)	Net	mm	990×765×1635	990×765×1635	990×765×1635	1340×765×1635
	Packing	mm	1030×825×1865	1030×825×1865	1030×825×1865	1395×815×1865
Weight	Net	kg	215	215	230	265
	Gross	kg	225	225	240	280
Pipe Diameter	Liquid Side	mm	12.7	12.7	12.7	15.88
	Gas Side	mm	22.2	22.2	22.2	28.6
Operation Range	Cooling	°C	-15~52	-15~52	-15~52	-15~52
	Heating	°C	-25~24	-25~24	-25~24	-25~24
Stuffing Quantity	20/40/40H	unit	14/28/28	14/28/28	14/28/28	11/22/22

VRV 6 Series 380~415V-50/60Hz

HP			16	18	20	22
Model			TVODH(16)5R1	TVODH(50)5R1	TVODH(56)5R1	TVODH(61)5R1
Combination	HP		16	18	20	22
Capacity	Cooling	kW	45	50.4	56	61.5
	Heating	kW	45	50.4	56	61.5
Electric Data	Power supply	V~,Hz,Ph	380~415,3,50/60	380~415,3,50/60	380~415,3,50/60	380~415,3,50/60
	Cooling input	kW	11.82	12.63	15.34	18.90
	EER	W/W	3.81	3.99	3.65	3.25
	Heating input	kW	9.78	11.69	13.83	15.44
	COP	W/W	4.60	4.31	4.05	3.98
	SEER		6.3	6.0	5.6	5.2
	SCOP		4.2	4.0	3.6	3.5
Performance	Air Flow Volume	m ³ /h	14000	16000	16000	16000
	Sound Pressure level	dB(A)	≤61	≤63	≤63	≤63
Compressor	Type		DC inverter	DC inverter	DC inverter	DC inverter
	Quantity		1	2	2	2
Fan motor	Type		DC motor	DC motor	DC motor	DC motor
	Quantity		2	2	2	2
Max. No. of Indoor Units	unit		26	30	33	36
Connection Ratio	%		50~200	50~200	50~200	50~200
Dimension (WxDxH)	Net	mm	1340×765×1635	1340×765×1635	1340×765×1635	1340×765×1635
	Packing	mm	1395×815×1865	1395×815×1865	1395×815×1865	1395×815×1865
Weight	Net	kg	265	330	330	330
	Gross	kg	280	345	345	345
Pipe Diameter	Liquid Side	mm	15.88	15.88	15.88	15.88
	Gas Side	mm	28.6	28.6	28.6	28.6
Operation Range	Cooling	°C	-15~52	-15~52	-15~52	-15~52
	Heating	°C	-25~24	-25~24	-25~24	-25~24
Stuffing Quantity	20/40/40H	unit	11/22/22	11/22/22	11/22/22	11/22/22

Notes:

- Cooling Capacity: Indoor temperature 27°C DB/19°C WB; Outdoor temperature:35°C DB/ 24°C WB.
- Heating Capacity: Indoor temperature 20°C DB; Outdoor temperature: 7°C DB/ 6°C WB.
- Piping Length: Equivalent piping length: 7.5m, level difference: 0m.
- We can guarantee the operation only within 130% Combination. If you want to connect more than 130% combination, please contact us and discuss the requirement.
- Anechoic chamber conversion value, measured in test room. During actual operation. These values are normally somewhat higher as a result of ambient conditions.
- The above designs and specifications are subject to change without prior notice. Final specifications please refer to technical specification provided by sales representative.
- Sound values are measured in a semi-anechoic room, at a position 1m in front of the unit and 1.3m above the floor.
- The above combined types are factory-recommended type. The combined type also can be combined at will.

VRV 6 Series 380~415V-50/60Hz

HP			24	26	28	30
Model			TVODH(67)5R1	TVODH(73)5R1	TVODH(78)5R1	TVODH(84)5R1
Combination	HP		12+12	10+16	12+16	10+20
Capacity	Cooling	kW	67	73	78.5	84
	Heating	kW	67	73	78.5	84
Electric Data	Power supply	V~,Hz,Ph	380~415,3,50/60	380~415,3,50/60	380~415,3,50/60	380~415,3,50/60
	Cooling input	kW	16.96	17.93	20.30	21.45
	EER	W/W	3.95	4.07	3.87	3.92
	Heating input	kW	12.76	15.01	16.16	19.06
	COP	W/W	5.25	4.86	4.86	4.41
	SEER		7.2	6.5	7.2	7.2
	SCOP		4.2	4.2	4.2	4.2
Performance	Air Flow Volume	m ³ /h	12000×2	12000+14000	12000+14000	12000+16000
	Sound Pressure level	dB(A)	≤58	≤61	≤61	≤63
Compressor	Type		DC inverter	DC inverter	DC inverter	DC inverter
	Quantity		2	2	2	3
Fan motor	Type		DC motor	DC motor	DC motor	DC motor
	Quantity		2	3	3	3
Max. No. of Indoor Units	unit		40	42	46	49
Connection Ratio	%		50~200	50~200	50~200	50~200
Dimension (WxDxH)	Net	mm	(990×765×1635)×2	990×765×1635+1340×765×1635	990×765×1635+1340×765×1635	990×765×1635+1340×765×1635
	Packing	mm	(1030×825×1865)×2	1030×825×1865+1395×815×1865	1030×825×1865+1395×815×1865	1030×825×1865+1395×815×1865
Weight	Net	kg	230×2	215+265	230+265	215+330
	Gross	kg	240×2	225+280	240+280	225+345
Pipe Diameter	Liquid Side	mm	15.88(5/8)	19.05(3/4)	19.05(3/4)	19.05(3/4)
	Gas Side	mm	28.6(9/8)	34.93(11/8)	34.93(11/8)	34.93(11/8)
Operation Range	Cooling	°C	-15~52	-15~52	-15~52	-15~52
	Heating	°C	-25~24	-25~24	-25~24	-25~24
Stuffing Quantity	20/40/40H	unit	14/28/28	14/28/28	14/28/28	11/22/22

VRV 6 Series 380~415V-50/60Hz

HP			32	34	36	38
Model			TVODH(89)5R1	TVODH(95)5R1	TVODH(101)5R1	TVODH(106)5R1
Combination	HP		10+22	12+22	14+22	16+22
Capacity	Cooling	kW	89.5	95	101.5	106.5
	Heating	kW	89.5	95	101.5	106.5
Electric Data	Power supply	V~,Hz,Ph	380~415,3,50/60	380~415,3,50/60	380~415,3,50/60	380~415,3,50/60
	Cooling input	kW	25.01	27.38	28.80	30.72
	EER	W/W	3.58	3.47	3.52	3.47
	Heating input	kW	20.67	21.82	23.69	25.22
	COP	W/W	4.33	4.35	4.28	4.22
	SEER		6.5	7.2	6.5	6.3
	SCOP		4.0	4.2	4.3	4.2
Performance	Air Flow Volume	m ³ /h	12000+16000	12000+16000	14000+16000	14000+16000
	Sound Pressure level	dB(A)	≤63	≤63	≤63	≤63
Compressor	Type		DC inverter	DC inverter	DC inverter	DC inverter
	Quantity		3	3	3	3
Fan motor	Type		DC motor	DC motor	DC motor	DC motor
	Quantity		3	3	4	4
Max. No. of Indoor Units	unit		52	56	59	62
Connection Ratio	%		50~200	50~200	50~200	50~200
Dimension (WxDxH)	Net	mm	990×765×1635+1340×765×1635	990×765×1635+1340×765×1635	(1340×765×1635)×2	(1340×765×1635)×2
	Packing	mm	1030×825×1865+1395×815×1865	1030×825×1865+1395×815×1865	(1395×815×1865)×2	(1395×815×1865)×2
Weight	Net	kg	215+330	230+330	265+330	265+330
	Gross	kg	225+345	240+345	280+345	280+345
Pipe Diameter	Liquid Side	mm	19.05(3/4)	19.05(3/4)	19.05(3/4)	19.05(3/4)
	Gas Side	mm	34.93(11/8)	34.93(11/8)	41.3(13/8)	41.3(13/8)
Operation Range	Cooling	°C	-15~52	-15~52	-15~52	-15~52
	Heating	°C	-25~24	-25~24	-25~24	-25~24
Stuffing Quantity	20/40/40H	unit	11/22/22	11/22/22	11/22/22	11/22/22

Notes:

- Cooling Capacity: Indoor temperature 27°C DB/19°C WB; Outdoor temperature:35°C DB/ 24°C WB.
- Heating Capacity: Indoor temperature 20°C DB; Outdoor temperature: 7°C DB/ 6°C WB.
- Piping Length: Equivalent piping length: 7.5m, level difference: 0m.
- We can guarantee the operation only within 130% Combination. If you want to connect more than 130% combination, please contact us and discuss the requirement.
- Anechoic chamber conversion value, measured in test room. During actual operation. These values are normally somewhat higher as a result of ambient conditions.
- The above designs and specifications are subject to change without prior notice. Final specifications please refer to technical specification provided by sales representative.
- Sound values are measured in a semi-anechoic room, at a position 1m in front of the unit and 1.3m above the floor.
- The above combined types are factory-recommended type. The combined type also can be combined at will.

VRV 6 Series 380~415V-50/60Hz

HP			40	42	44	46
Model			TVODH(112)5R1	TVODH(117)5R1	TVODH(123)5R1	TVODH(128)5R1
Combination	HP		18+22	20+22	22+22	12×2+22
Capacity	Cooling	kW	111.9	117.5	123	128.5
	Heating	kW	111.9	117.5	123	128.5
Electric Data	Power supply	V~,Hz,Ph	380~415,3,50/60	380~415, 3, 50/60	380~415, 3, 50/60	380~415, 3, 50/60
	Cooling input	kW	31.53	34.24	37.80	35.86
	EER	W/W	3.55	3.43	3.25	3.58
	Heating input	kW	27.13	29.27	30.88	28.20
	COP	W/W	4.12	4.01	3.98	4.56
	SEER		6.0	5.6	5.2	7.2
	SCOP		4.0	3.6	3.5	4.2
Performance	Air Flow Volume	m ³ /h	16000×2	16000×2	16000×2	12000×2+16000
	Sound Pressure level	dB(A)	≤63	≤63	≤63	≤63
Compressor	Type		DC inverter	DC inverter	DC inverter	DC inverter
	Quantity		4	4	4	4
Fan motor	Type		DC motor	DC motor	DC motor	DC motor
	Quantity		4	4	4	4
Max. No. of Indoor Units	unit		64	64	64	64
Connection Ratio	%		50~200	50~200	50~200	50~200
Dimension (WxDxH)	Net	mm	(1340×765×1635)×2	(1340×765×1635)×2	(1340×765×1635)×2	(990×765×1635)×2+1340×765×1635
	Packing	mm	(1395×815×1865)×2	(1395×815×1865)×2	(1395×815×1865)×2	(1050×815×1805)×2+1395×815×1865
Weight	Net	kg	330×2	330×2	330×2	230×2+330
	Gross	kg	345×2	345×2	345×2	240×2+345
Pipe Diameter	Liquid Side	mm	19.05(3/4)	19.05(3/4)	19.05(3/4)	19.05(3/4)
	Gas Side	mm	41.3(13/8)	41.3(13/8)	41.3(13/8)	41.3(13/8)
Operation Range	Cooling	°C	-15~52	-15~52	-15~52	-15~52
	Heating	°C	-25~24	-25~24	-25~24	-25~24

VRV 6 Series 380~415V-50/60Hz

HP			48	50	52	54
Model			TVODH(134)5R1	TVODH(140)5R1	TVODH(145)5R1	TVODH(151)5R1
Combination	HP		10+16+22	12+16+22	10+20+22	10+22×2
Capacity	Cooling	kW	134.5	140	145.5	151
	Heating	kW	134.5	140	145.5	151
Electric Data	Power supply	V~,Hz,Ph	380~415, 3, 50/60	380~415, 3, 50/60	380~415, 3, 50/60	380~415, 3, 50/60
	Cooling input	kW	36.83	39.20	40.35	43.91
	EER	W/W	3.65	3.57	3.61	3.44
	Heating input	kW	30.45	31.60	34.50	36.11
	COP	W/W	4.42	4.43	4.22	4.18
	SEER		6.5	7.2	6.5	6.5
	SCOP		4.2	4.2	4.0	4.0
Performance	Air Flow Volume	m ³ /h	12000+14000+16000	12000+14000+16000	12000+16000×2	12000+16000×2
	Sound Pressure level	dB(A)	≤63	≤63	≤63	≤63
Compressor	Type		DC inverter	DC inverter	DC inverter	DC inverter
	Quantity		4	4	5	5
Fan motor	Type		DC motor	DC motor	DC motor	DC motor
	Quantity		5	5	5	5
Max. No. of Indoor Units	unit		64	64	64	64
Connection Ratio	%		50~200	50~200	50~200	50~200
Dimension (WxDxH)	Net	mm	990×765×1635+(1340×765×1635)×2	990×765×1635+(1340×765×1635)×2	990×765×1635+(1340×765×1635)×2	990×765×1635+(1340×765×1635)×2
	Packing	mm	1050×815×1805+(1395×815×1865)×2	1050×815×1805+(1395×815×1865)×2	1050×815×1805+(1395×815×1865)×2	1050×815×1805+(1395×815×1865)×2
Weight	Net	kg	215+265+330	230+265+330	215+330×2	215+330×2
	Gross	kg	225+280+345	240+280+345	225+345×2	225+345×2
Pipe Diameter	Liquid Side	mm	19.05(3/4)	19.05(3/4)	22.2(7/8)	22.2(7/8)
	Gas Side	mm	41.3(13/8)	41.3(13/8)	47.6(15/8)	47.6(15/8)
Operation Range	Cooling	°C	-15~52	-15~52	-15~52	-15~52
	Heating	°C	-25~24	-25~24	-25~24	-25~24

Notes:

- Cooling Capacity: Indoor temperature 27°C DB/19°C WB; Outdoor temperature:35°C DB/ 24°C WB.
- Heating Capacity: Indoor temperature 20°C DB; Outdoor temperature: 7°C DB/ 6°C WB.
- Piping Length: Equivalent piping length: 7.5m, level difference: 0m.
- We can guarantee the operation only within 130% Combination. If you want to connect more than 130% combination, please contact us and discuss the requirement.
- Anechoic chamber conversion value, measured in test room. During actual operation. These values are normally somewhat higher as a result of ambient conditions.
- The above designs and specifications are subject to change without prior notice. Final specifications please refer to technical specification provided by sales representative.
- Sound values are measured in a semi-anechoic room, at a position 1m in front of the unit and 1.3m above the floor.
- The above combined types are factory-recommended type. The combined type also can be combined at will.

VRV 6 Series 380~415V-50/60Hz

HP			56	58	60	62
Model			TVODH(156)5R1	TVODH(163)5R1	TVODH(168)5R1	TVODH(173)5R1
Combination	HP		12+22×2	14+22×2	16+22×2	18+22×2
Capacity	Cooling	kW	156.5	163	168	173.4
	Heating	kW	156.5	163	168	173.4
Electric Data	Power supply	V~,Hz,Ph	380~415,3,50/60	380~415, 3, 50/60	380~415, 3, 50/60	380~415, 3, 50/60
	Cooling input	kW	46.28	47.70	49.62	50.43
	EER	W/W	3.38	3.42	3.39	3.44
	Heating input	kW	37.26	39.13	40.66	42.57
	COP	W/W	4.20	4.17	4.13	4.07
	SEER		7.2	6.5	6.3	6.0
	SCOP		4.2	4.3	4.2	4.0
Performance	Air Flow Volume	m ³ /h	12000+16000×2	14000+16000×2	14000+16000×2	16000×3
	Sound Pressure level	dB(A)	≤63	≤63	≤63	≤63
Compressor	Type		DC inverter	DC inverter	DC inverter	DC inverter
	Quantity		5	5	5	6
Fan motor	Type		DC motor	DC motor	DC motor	DC motor
	Quantity		5	6	6	6
Max. No. of Indoor Units	unit		64	64	64	64
Connection Ratio	%		50~200	50~200	50~200	50~200
Dimension (WxDxH)	Net	mm	990×765×1635+(1340×765×1635)×2	(1340×765×1635)×3	(1340×765×1635)×3	(1340×765×1635)×3
	Packing	mm	1050×815×1805+(1395×815×1865)×2	(1395×815×1865)×3	(1395×815×1865)×3	(1395×815×1865)×3
Weight	Net	kg	230+330×2	265+330×2	265+330×2	330×3
	Gross	kg	240+345×2	280+345×2	280+345×2	345×3
Pipe Diameter	Liquid Side	mm	22.2(7/8)	22.2(7/8)	22.2(7/8)	22.2(7/8)
	Gas Side	mm	47.6(15/8)	47.6(15/8)	47.6(15/8)	47.6(15/8)
Operation Range	Cooling	°C	-15~52	-15~52	-15~52	-15~52
	Heating	°C	-25~24	-25~24	-25~24	-25~24

VRV 6 Series 380~415V-50/60Hz

HP			64	66	68	70
Model			TVODH(179)5R1	TVODH(184)5R1	TVODH(190)5R1	TVODH(196)5R1
Combination	HP		20+22×2	22×3	12×2+22×2	10+16+22×2
Capacity	Cooling	kW	179	184.5	190	196
	Heating	kW	179	184.5	190	196
Electric Data	Power supply	V~,Hz,Ph	380~415, 3, 50/60	380~415, 3, 50/60	380~415, 3, 50/60	380~415, 3, 50/60
	Cooling input	kW	53.14	56.70	54.76	55.73
	EER	W/W	3.37	3.25	3.47	3.52
	Heating input	kW	44.71	46.32	43.64	45.89
	COP	W/W	4.00	3.98	4.35	4.27
	SEER		5.6	5.2	7.2	6.5
	SCOP		3.6	3.5	4.2	4.2
Performance	Air Flow Volume	m ³ /h	16000×3	16000×3	12000×2+16000×2	12000+14000+16000×2
	Sound Pressure level	dB(A)	≤63	≤63	≤63	≤63
Compressor	Type		DC inverter	DC inverter	DC inverter	DC inverter
	Quantity		6	6	6	6
Fan motor	Type		DC motor	DC motor	DC motor	DC motor
	Quantity		6	6	6	7
Max. No. of Indoor Units	unit		64	64	64	64
Connection Ratio	%		50~200	50~200	50~200	50~200
Dimension (WxDxH)	Net	mm	(1340×765×1635)×3	(1340×765×1635)×3	(990×765×1635)×2+(1340×765×1635)×2	990×765×1635+(1340×765×1635)×3
	Packing	mm	(1395×815×1865)×3	(1395×815×1865)×3	(1050×815×1805)×2+(1395×815×1865)×2	1050×815×1805+(1395×815×1865)×3
Weight	Net	kg	330×3	330×3	230×2+330×2	215+265+330×2
	Gross	kg	345×3	345×3	240×2+345×2	225+280+345×2
Pipe Diameter	Liquid Side	mm	22.2(7/8)	22.2(7/8)	22.2(7/8)	22.2(7/8)
	Gas Side	mm	47.6(15/8)	47.6(15/8)	47.6(15/8)	47.6(15/8)
Operation Range	Cooling	°C	-15~52	-15~52	-15~52	-15~52
	Heating	°C	-25~24	-25~24	-25~24	-25~24

Notes:

- Cooling Capacity: Indoor temperature 27°C DB/19°C WB; Outdoor temperature:35°C DB/ 24°C WB.
- Heating Capacity: Indoor temperature 20°C DB; Outdoor temperature: 7°C DB/ 6°C WB.
- Piping Length: Equivalent piping length: 7.5m, level difference: 0m.
- We can guarantee the operation only within 130% Combination. If you want to connect more than 130% combination, please contact us and discuss the requirement.
- Anechoic chamber conversion value, measured in test room. During actual operation. These values are normally somewhat higher as a result of ambient conditions.
- The above designs and specifications are subject to change without prior notice. Final specifications please refer to technical specification provided by sales representative.
- Sound values are measured in a semi-anechoic room, at a position 1m in front of the unit and 1.3m above the floor.
- The above combined types are factory-recommended type. The combined type also can be combined at will.

VRV 6 Series 380~415V-50/60Hz

HP			72	74	76	78
Model			TVODH(201)5R1	TVODH(207)5R1	TVODH(212)5R1	TVODH(218)5R1
Combination	HP		12+16+22×2	10+20+22×2	10+22×3	12+22×3
Capacity	Cooling	kW	201.5	207	212.5	218
	Heating	kW	201.5	207	212.5	218
Electric Data	Power supply	V~,Hz,Ph	380~415,3,50/60	380~415, 3, 50/60	380~415, 3, 50/60	380~415, 3, 50/60
	Cooling input	kW	58.10	59.25	62.81	65.18
	EER	W/W	3.47	3.49	3.38	3.34
	Heating input	kW	47.04	49.94	51.55	52.70
	COP	W/W	4.28	4.14	4.12	4.14
	SEER		7.2	6.5	6.5	7.2
	SCOP		4.2	4.0	4.0	4.2
Performance	Air Flow Volume	m³/h	12000+14000+16000×2	12000+16000×3	12000+16000×3	12000+16000×3
	Sound Pressure level	dB(A)	≤63	≤63	≤63	≤63
Compressor	Type		DC inverter	DC inverter	DC inverter	DC inverter
	Quantity		6	7	7	7
Fan motor	Type		DC motor	DC motor	DC motor	DC motor
	Quantity		7	7	7	7
Max. No. of Indoor Units	unit		64	64	64	64
Connection Ratio	%		50~200	50~200	50~200	50~200
Dimension (WxDxH)	Net	mm	990×765×1635+(1340×765×1635)×3	990×765×1635+(1340×765×1635)×3	990×765×1635+(1340×765×1635)×3	990×765×1635+(1340×765×1635)×3
	Packing	mm	1050×815×1805+(1395×815×1865)×3	1050×815×1805+(1395×815×1865)×3	1050×815×1805+(1395×815×1865)×3	1050×815×1805+(1395×815×1865)×3
Weight	Net	kg	230+265+330×2	215+330×3	215+330×3	230+330×3
	Gross	kg	240+280+345×2	225+345×3	225+345×3	240+345×3
Pipe Diameter	Liquid Side	mm	22.2(7/8)	22.2(7/8)	22.2(7/8)	22.2(7/8)
	Gas Side	mm	47.6(15/8)	47.6(15/8)	47.6(15/8)	47.6(15/8)
Operation Range	Cooling	°C	-15~52	-15~52	-15~52	-15~52
	Heating	°C	-25~24	-25~24	-25~24	-25~24

VRV 6 Series 380~415V-50/60Hz

HP			80	82	84	86	88
Model			TVODH(224)5R1	TVODH(229)5R1	TVODH(235)5R1	TVODH(240)5R1	TVODH(246)5R1
Combination	HP		14+22×3	16+22×3	18+22×3	20+22×3	22×4
Capacity	Cooling	kW	224.5	229.5	234.9	240.5	246
	Heating	kW	224.5	229.5	234.9	240.5	246
Electric Data	Power supply	V~,Hz,Ph	380~415, 3, 50/60	380~415, 3, 50/60	380~415, 3, 50/60	380~415, 3, 50/60	380~415,3,50/60
	Cooling input	kW	66.60	68.52	69.33	72.04	75.60
	EER	W/W	3.37	3.35	3.39	3.34	3.25
	Heating input	kW	54.57	56.10	58.01	60.15	61.76
	COP	W/W	4.11	4.09	4.05	4.00	3.98
	SEER		6.5	6.3	6.0	5.6	5.2
	SCOP		4.3	4.2	4.0	3.6	3.5
Performance	Air Flow Volume	m³/h	14000+16000×3	14000+16000×3	16000×4	16000×4	16000×4
	Sound Pressure level	dB(A)	≤63	≤63	≤63	≤63	≤63
Compressor	Type		DC inverter	DC inverter	DC inverter	DC inverter	DC inverter
	Quantity		7	7	8	8	8
Fan motor	Type		DC motor	DC motor	DC motor	DC motor	DC motor
	Quantity		8	8	8	8	8
Max. No. of Indoor Units	unit		64	64	64	64	64
Connection Ratio	%		50~200	50~200	50~200	50~200	50~200
Dimension (WxDxH)	Net	mm	(1340×765×1635)×4	(1340×765×1635)×4	(1340×765×1635)×4	(1340×765×1635)×4	(1340×765×1635)×4
	Packing	mm	(1395×815×1865)×4	(1395×815×1865)×4	(1395×815×1865)×4	(1395×815×1865)×4	(1395×815×1865)×4
Weight	Net	kg	265+330×3	265+330×3	330×4	330×4	330×4
	Gross	kg	280+345×3	280+345×3	345×4	345×4	345×4
Pipe Diameter	Liquid Side	mm	22.2(7/8)	22.2(7/8)	22.2(7/8)	22.2(7/8)	22.2(7/8)
	Gas Side	mm	47.6(15/8)	47.6(15/8)	47.6(15/8)	47.6(15/8)	47.6(15/8)
Operation Range	Cooling	°C	-15~52	-15~52	-15~52	-15~52	-15~52
	Heating	°C	-25~24	-25~24	-25~24	-25~24	-25~24

Notes:

- Cooling Capacity: Indoor temperature 27°C DB/19°C WB; Outdoor temperature:35°C DB/ 24°C WB.
- Heating Capacity: Indoor temperature 20°C DB; Outdoor temperature: 7°C DB/ 6°C WB.
- Piping Length: Equivalent piping length: 7.5m, level difference: 0m.
- We can guarantee the operation only within 130% Combination. If you want to connect more than 130% combination, please contact us and discuss the requirement.
- Anechoic chamber conversion value, measured in test room. During actual operation. These values are normally somewhat higher as a result of ambient conditions.
- The above designs and specifications are subject to change without prior notice. Final specifications please refer to technical specification provided by sales representative.
- Sound values are measured in a semi-anechoic room, at a position 1m in front of the unit and 1.3m above the floor.
- The above combined types are factory-recommended type. The combined type also can be combined at will.

VRV Individual Series 380~415V-50Hz

HP			22	24	26	28	30	32
Model	Outdoor	50Hz	TVOLH(62)5R1	TVOLH(67)5R1	TVOLH(73)5R1	TVOLH(78)5R1	TVOLH(85)5R1	TVOLH(90)5R1
Capacity	Cooling	kW	61.5	67	73	78.5	85	90
	Heating	kW	69	75	81.5	87.5	95	100
Electric Data	Power supply	V~,Hz,Ph	380~415, 50, 3	380~415, 50, 3	380~415, 50, 3	380~415, 50, 3	380~415, 50, 3	380~415, 50, 3
	Cooling input	kW	18.67	20.1	21.9	23.7	25.8	27.5
	EER	W/W	3.29	3.33	3.33	3.31	3.29	3.27
	Heating input	kW	17.75	19.3	20.2	22	24.4	26.3
	COP	W/W	3.89	3.89	4.03	3.98	3.89	3.80
	Performance	Air Flow Volume	m³/h	21000	21000	28000	28000	30000
	Sound Pressure level	dB(A)	≤63	≤63	≤65	≤65	≤65	≤65
Compressor	Type		DC inverter	DC inverter	DC inverter	DC inverter	DC inverter	DC inverter
	Quantity		2	2	2	2	2	2
Fan Motor	Type		AC motor	AC motor	AC motor	AC motor	AC motor	AC motor
	Quantity		2	2	2	2	2	2
Max. No. of Indoor Units	unit		36	39	43	46	50	53
Connection Ratio	%		50~130%	50~130%	50~130%	50~130%	50~130%	50~130%
Dimension (WxDxH)	Net	mm	1590×765×1600	1590×765×1600	2350×765×1600	2350×765×1600	2350×765×1600	2350×765×1600
	Packing	mm	1650×815×1770	1650×815×1770	2410×815×1770	2410×815×1770	2410×815×1770	2410×815×1770
Weight	Net	kg	400	400	500	500	500	500
	Gross	kg	420	420	515	515	515	515
Refrigerant Type			R410A	R410A	R410A	R410A	R410A	R410A
Pipe Diameter	Liquid Side	mm	15.88	15.88	19.05	19.05	19.05	19.05
	Gas Side	mm	28.6	28.6	34.9	34.9	34.9	34.9
Operation Range	Cooling	°C	-5~52	-5~52	-5~52	-5~52	-5~52	-5~52
	Heating	°C	-20~27	-20~27	-20~27	-20~27	-20~27	-20~27
Stuffing Quantity	20/40/40H	unit	7/14/14	7/14/14	4/8/8	4/8/8	4/8/8	4/8/8

Notes:

- Cooling Capacity: Indoor temperature 27°C DB/19°C WB; Outdoor temperature: 35°C DB/ 24°C WB.
- Heating Capacity: Indoor temperature 20°C DB; Outdoor temperature: 7°C DB/ 6°C WB.
- Piping Length: Equivalent piping length: 7.5m, level difference: 0m.
- Anechoic chamber conversion value, measured in test room. During actual operation. These values are normally somewhat higher as a result of ambient conditions.
- The above designs and specifications are subject to change without prior notice. Final specifications please refer to technical specification provided by sales representative.
- Sound values are measured in a semi-anechoic room, at a position 1m in front of the unit and 1.3m above the floor.

MINI VRV Series

Experience ultimate comfort at home or work with powerful yet economical performance

Combines world-class energy efficiency and economy to deliver outstanding performance in a space-saving design. Supporting up to nine indoor units, VRV is a perfectly optimized cooling system for residences and smaller buildings. It's light weight small-scale build enables easy, low cost installation, while it's uniquely quiet design ensures soothing comfort and maximum efficiency. Plus, the VRV line offers a wide range of capacities to suit every need.

- First-rate energy efficiency. Save on energy consumption and operational costs with high-performance compressor technology.
- Low noise levels. Enjoy a more peaceful home or work environment with quiet operation, thanks to a streamlined fan design.
- Various installation options. Ease installation and minimize effort with a small footprint and a variety of size options.



Big capacity. Big choice.

World's largest capacity and most compact sidedischarge outdoor unit, which also offers a high level of energy efficiency. It's ideal for homes or business that need plenty of coverage, but only have limited space.

Best in class capacity

Provides more coverage, but takes up less space. It has the largest capacity in its class of 14HP, enabling you to create a small footprint VRV solution. So it's ideal for installation in places with limited space.

Compact design for extra flexibility

The most compact air conditioner in its class, making it very easy and economical to install and operate without compromising on performance. It also leaves plenty of extra space that can be used for other purposes.



Advanced performance & energy efficiency

Its advanced technology radically improves performance and reduces wasted energy. It includes an innovative Digital Inverter Compressor, an optimized heat exchanger with corrugated fins and highly efficient fans.



Improved reliability in cold conditions

Featuring advanced refrigerant control technology, its flash injection provides improved heating performance at -25°C. And it continues to perform even at lower temperatures, for reliable comfort when it's freezing.



Control your cooling anywhere

An optional Wi-Fi Kit lets you remotely control indoor units using a smartphone App. Anytime and anywhere you can turn them on and off, select the operating mode and temperature, and utilize their other functions.

* Available on iPhones and Android devices. A Wi-Fi connection is required.

Long Piping Length

- Max. Total piping length — 100/150m
- Max. Actual piping length — 60/100m
- Max. Level difference between indoor units — 10/15m
- Max. Level difference between ODU and IDU units — 40/50m
- Max. piping length from 1st indoor branch to the farthest indoor unit — 20m/40m

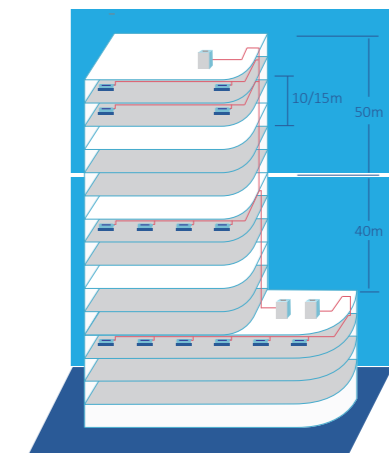

Drive down costs and energy use with unmatched efficiency

today's eco- and budget-conscious businesses. Using advanced compressor technology, it offers industry-leading COP, which means exceptional heating and cooling performance at a nominal cost.

Energy-efficient compression

a higher cooling and heating COP than that of a conventional model. The result is one of the most efficient air conditioning systems on the market and a smart investment for cost-conscious businesses.



Enjoy minimal noise levels for maximum comfort

With its superior design, offers a comforting environment undisturbed by bothersome noise levels typical of standard air conditioning systems. Residents can enjoy a more restful night and employees can increase focus levels with less disturbance.

Ultra-quiet operation

By producing less noise than conventional models, the imposes fewer distractions on residential and working environments. Its compact, unimposing design and specially shaped fan blades help reduce sound levels up to 5 decibels, creating a more pleasant. Plus, its quiet operation during the night time creates a restful environment with a reduced noise level of 2 - 8 dB.

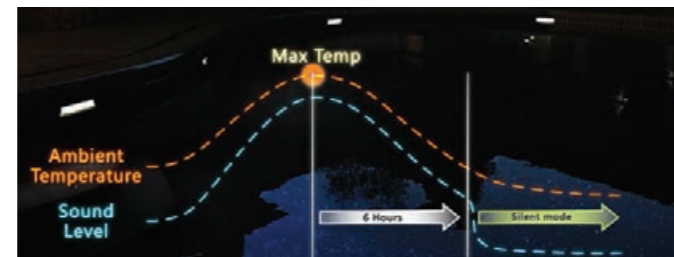

All DC Inverter 50Hz/60Hz

Model	Outdoor		TVOMH(8)4R1	TVOMH(10)4R1	TVOMH(12)4R1	TVOMH(14)4R1	TVOMH(16)4R1
Capacity	Cooling	kW	8.00	10.00	12.30	14.00	16.00
	Heating	kW	9.00	11.50	13.20	16.50	18.00
Electric Data	Power Supply	V~,Hz,Ph	220~240,50/60,1	220~240,50/60,1	220~240,50/60,1	220~240,50/60,1	220~240,50/60,1
	Cooling Power Input	kW	2.30	3.00	3.25	3.95	4.80
	Heating Power Input	kW	2.40	3.20	3.41	4.05	4.80
	Cooling Current	A	10.10	13.20	14.30	17.30	21.10
	Heating Current	A	10.50	14.00	15.00	17.80	21.10
	EER		3.48	3.33	3.78	3.54	3.33
Performance	COP		3.75	3.59	3.87	4.07	3.75
	SEER		6.20	6.10	6.10	6.10	6.10
	SCOP		4.20	4.10	4.10	4.00	4.00
	Air Flow Volume	m ³ /h	4154	4154	7200	7200	7200
Piping Limite	Noise Level	dB(A)	56	56	57	57	57
	Level difference between IDU and ODU	m	50	50	50	50	50
	Level difference between IDU and IDU	m	10	10	15	15	15
	Between the first brance and the Farthest IDU	m	40	40	40	40	40
Total Pipe length	m	100	100	150	150	150	
Max. No. of Indoor Units	unit	4	5	7	8	9	
Connection Ratio	%	50~130	50~130	50~130	50~130	50~130	
Dimension (WxDxH)	Net	mm	970×395×805	970×395×805	940×370×1325	940×370×1325	940×370×1325
	Packing	mm	1105×495×895	1105×495×895	1080×430×1440	1080×430×1440	1080×430×1440
Weight	Net	kg	66	66	86	86	93
	Gross	kg	71	71	91	91	98
Refrigerant Type			R410a	R410a	R410a	R410a	R410a
Pipe Diameter	Liquid Side	mm(inch)	9.52(3/8)	9.52(3/8)	9.52(3/8)	9.52(3/8)	9.52(3/8)
	Gas Side	mm(inch)	15.88(5/8)	15.88(5/8)	15.88(5/8)	15.88(5/8)	19.05(3/4)
Operation Range	Cooling	°C	-15~52	-15~52	-15~52	-15~52	-15~52
	Heating	°C	-15~27	-15~27	-15~27	-15~27	-15~27
Stuffing Quantity	20/40/40H	unit	44/96/144	44/96/144	26/54/54	26/54/54	26/54/54

ARV Mini Series 50Hz

Model	Outdoor		TVOMH(22)5R1	TVOMH(26)5R1
Capacity	Cooling	kW	22.40	26.00
	Heating	kW	24.50	28.50
Electric Data	Power Supply	V~,Hz,Ph	380~415,50,3	380~415,50,3
	Cooling Power Input	kW	7.20	8.40
	Heating Power Input	kW	6.70	7.90
	Cooling Current	A	11.60	13.50
	Heating Current	A	11.00	13.00
	EER		3.11	3.10
Performance	COP		3.66	3.61
	Air Flow Volume	m ³ /h	9000	9000
	Noise Level	dB(A)	60	60
Piping Limit	Vertical Pipe Length	m	≤30	≤30
	Actual Pipe Length	m	45	45
	Equivalent Pipe Length	m	50	50
	Total Pipe length	m	100	100
Max. No. of Indoor Units	unit	11	12	
Connection Ratio	%	50~130	50~130	
Dimension (WxDxH)	Net	mm	1120×400×1510	1120×400×1510
	Packing	mm	1270×560×1710	1270×560×1710
Weight	Net	kg	150	150
	Gross	kg	170	170
Refrigerant Type			R410a	R410a
Pipe Diameter	Liquid Side	mm(inch)	9.52(3/8)	9.52(3/8)
	Gas Side	mm(inch)	22.22(7/8)	22.22(7/8)
Operation Range	Cooling	°C	-10~52	-10~52
	Heating	°C	-15~24	-15~24
Stuffing Quantity	20/40/40H	unit	17/37/37	17/37/37

Notes:
 1.Cooling Capacity: Indoor temperature 27°C DB/ 19°C WB; Outdoor temperature:35°C DB/ 24°C WB.
 2.Cooling Capacity (Tropical): Indoor temperature 27°C DB/19°C WB,Outdoor temperature:46.1°C DB.
 3.Heating Capacity: Indoor temperature 20°C DB; Outdoor temperature: 7°C DB/ 6°C WB.
 4.Piping Length: Equivalent piping length: 7.5m, level difference: 0m.
 5.Anechoic chamber conversion value, measured in test room. During actual operation. These values are normally somewhat higher as a result of ambient c onditions.
 6.The above designs and specifications are subject to change without prior notice. Final specifications please refer to technical specification provided by sales representative.

Cassette Type	31
4Way Cassette S	31
Slim 1Way Cassette	35
2Way Cassette	39
Ducted Type	43
Duct S	44
Slim duct	49
MSP Duct	51
HSP Duct	53
Outdoor Air Processing Duct	55
Wall Mount Type	57
Console Type	59
Ceiling Type	60
Concealed Floor Standing	63
DVM S Hydro Unit	65
(Maldives) ERV/ERV Plus	65



Stage a beautiful yet comfortable environment

With its newly improved design, 4Way Cassette S supports a clean, aesthetically appealing atmosphere and adds a sense of sophistication to work and living spaces. Not only is this unit attractively designed, but it also uses advanced technologies to optimize comfort in any environment.

The TOYO 4Way Cassette S indoor air conditioning system delivers polish, comfort and efficiency with features such as:

- Stylishly clean design. Add panache to interior spaces with a choice of clean, streamlined panel patterns in a lightweight build.
- Robust operation. Control the atmosphere perfectly with an advanced design for superior air flow and cooling/heating.
- Low maintenance and simple installation. Ease installation and minimize maintenance with a detachable, no-drip design.



Complement any interior with a sleek, lightweight design

The TOYO 4Way Cassette S indoor air conditioner comes in a choice of patterns with a simple panel to better match the interior design. Its uniquely lightweight frame makes installation easy, while clever blade construction keeps the unit clean for a tidy appearance.

Waffle Pattern



Classic Pattern



Aesthetic panel and display

4Way Cassette S offers two different pattern designs for the panel. Users can select either the Waffle or Classic pattern to create just the right look to suit their design preference. Plus, the simple display design with rounded corners adds a chic sophistication to the interior.

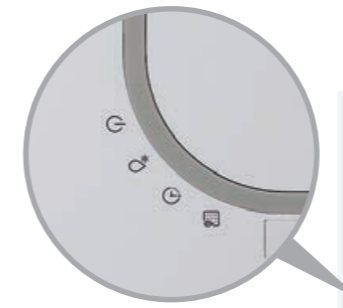

Power Defrost Time Clean

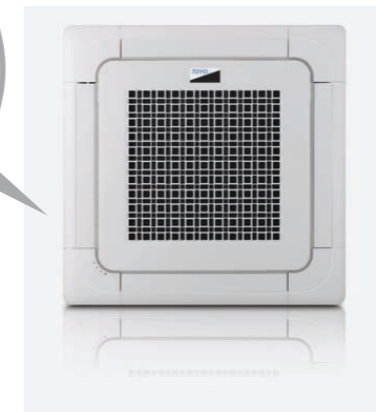

Neat and clean design

The indoor 4Way Cassette S boasts a smart design that promotes a neat and clean look. The completely hermetic blade structure keeps the indoor unit clean by preventing dust or other foreign substances from entering it. The internal parts of the indoor unit are also out of sight when the blade is shut, thus improving the unit's appearance.

Lightweight build

The TOYO 4Way Cassette S indoor unit is now lighter in weight at 17 kg. It is one of the lightest indoor units in the industry, about 40 percent lighter than conventional products.

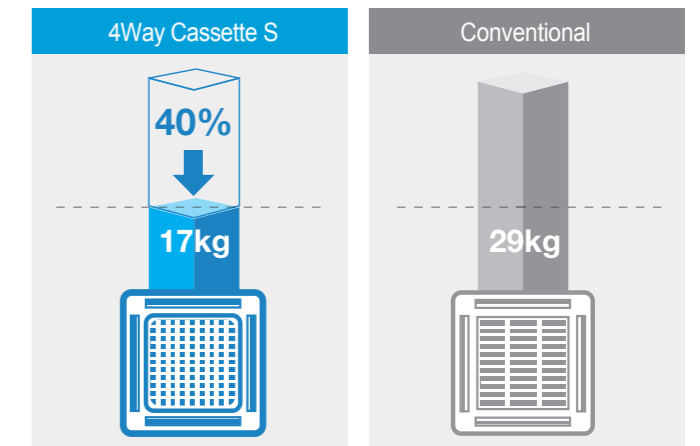

*Based on 10kW

Four-Way Cassette

Achieve peak performance with optimal airflow and superior control

Integrating the most advanced technologies 4Way Cassette S delivers easy, efficient comfort with specialized blade control, adjustable operation and powerful airflow. And optional Virus Doctor extends the unit's efficiency with air sanitation technology for a healthier atmosphere.

Individual blade control

TOYO 4Way Cassette S features a remote controller that enables users to manipulate the angles of the fan blades for more efficient cooling. With the remote controller, users can individually set the opening angles of the four blades at the same angle or different angles within a 32° - 65° range to create just the right atmosphere.

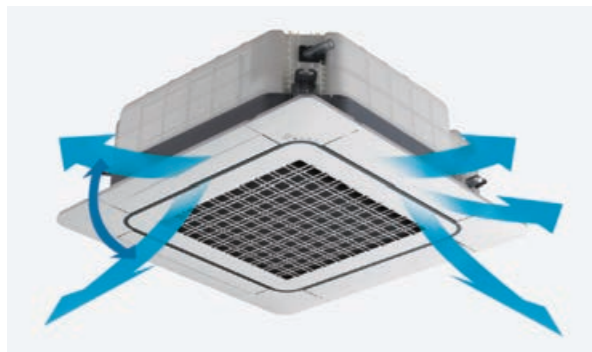

Optimal airflow for high ceilings

Using only the remote controller, operators can achieve optimum fan speed for high ceilings without adjusting the dual inline package (DIP) switch on the printed circuit board (PCB). The fan speed adjustment function evenly distributes cool and warm air throughout spaces with high ceilings of up to 3.5 m. And the high ceiling mode delivers even more powerful airflow throughout the interior space, enlarging the airflow coverage area for heights of up to 4.6 m.



Quiet, uniform air distribution

The aerodynamically designed Turbo Fan minimizes blade movement noise, meaning that 4Way Cassette S is noticeably quieter than conventional models. Plus, the Turbo Fan's wide blades provide evenly distributed extreme cooling and heating from four separate outlets so the entire room cools down or warms up faster.

Full-surround airflow

The 4-way outlet can cool every corner of the room. The new and practical design of the blades minimizes blind spots at the corners of the panel, and can cover nearly a full 360° around the indoor unit.

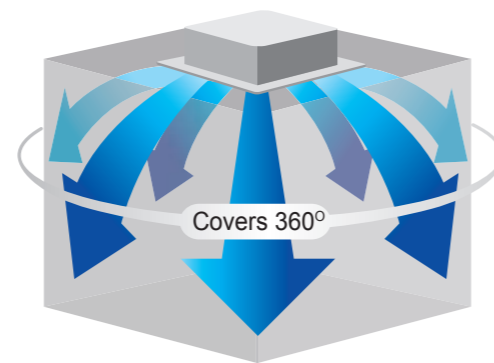

Cleaner, healthier air

Users can sanitize indoor air with the optional Virus Doctor for a cleaner work or living environment. The easy-to-install Virus Doctor generates active hydrogen and oxygen ions to eliminate airborne contaminants, completely eradicate airborne bacteria and allergens, and even neutralize OH(hydroxyl) radicals.

Specification-50Hz AC fan motor

Model	Indoor		TVFCH(7.1)4R1	TVFCH(8)4R1	TVFCH(9)4R1	TVFCH(10)4R1	TVFCH(11.2)4R1	TVFCH(12.5)4R1	TVFCH(14)4R1
Capacity	Cooling	kW	7.1	8.0	9.0	10.0	11.2	12.5	14.0
	Heating	kW	8.0	10.0	11.0	12.0	12.8	13.3	15.0
Electric Data	Power Supply	V~,Hz,Ph	220~240,50,1	220~240,50,1	220~240,50,1	220~240,50,1	220~240,50,1	220~240,50,1	220~240,50,1
	Rated Power	W	100	100	176	176	200	200	200
Performance	Air Flow Volume(Hi/Mid/Low)	m³/h	1250/1040/910	1250/1040/910	1500/1200/1050	1500/1200/1050	1800/1440/1260	1800/1440/1260	1800/1440/1260
	Noise Level(Hi/Mid/Low)	dB(A)	38/34/30	38/34/30	41/37/34	41/37/34	41/38/35	41/38/35	41/38/35
Dimension (WxDxH)	Net(Body)	mm	835×835×250	835×835×250	835×835×250	835×835×250	835×835×290	835×835×290	835×835×290
	Packing(Body)	mm	910×910×310	910×910×310	910×910×310	910×910×310	910×910×350	910×910×350	910×910×350
	Net(Panel)	mm	950×950×55	950×950×55	950×950×55	950×950×55	950×950×55	950×950×55	950×950×55
	Packing(Panel)	mm	1000×1000×100	1000×1000×100	1000×1000×100	1000×1000×100	1000×1000×100	1000×1000×100	1000×1000×100
Weight	Net/Gross(Body)	kg	27/34	27/34	28/35	28/35	30/37	30/37	30/37
	Net/Gross(Panel)	kg	5/7	5/7	5/7	5/7	5/7	5/7	5/7
Refrigerant Type			R410A	R410A	R410A	R410A	R410A	R410A	R410A
Pipe Diameter	Liquid Side	mm(inch)	9.52(3/8)	9.52(3/8)	9.52(3/8)	9.52(3/8)	9.52(3/8)	9.52(3/8)	9.52(3/8)
	Gas Side	mm(inch)	15.88(5/8)	15.88(5/8)	15.88(5/8)	15.88(5/8)	15.88(5/8)	15.88(5/8)	15.88(5/8)
	Drainage	mm(inch)	DN20(R3/4)	DN20(R3/4)	DN20(R3/4)	DN20(R3/4)	DN20(R3/4)	DN20(R3/4)	DN20(R3/4)
Stuffing Quantity		unit	78/168/184	78/168/184	78/168/184	78/168/184	68/150/170	68/150/170	68/150/170

Specification-60Hz AC fan motor

Model	Indoor		TVFCH(7.1)2R1	TVFCH(8)2R1	TVFCH(9)2R1	TVFCH(10)2R1	TVFCH(11.2)2R1	TVFCH(12.5)2R1	TVFCH(14)2R1
Capacity	Cooling	kW	7.1	8.0	9.0	10.0	11.2	12.5	14.0
	Heating	kW	8.0	10.0	11.0	12.0	12.8	13.3	15.0
Electric Data	Power Supply	V~,Hz,Ph	220~240,60,1	220~240,60,1	220~240,60,1	220~240,60,1	220~240,60,1	220~240,60,1	220~240,60,1
	Rated Power	W	95	95	122	122	165	165	165
Performance	Air Flow Volume(Hi/Mid/Low)	m³/h	1250/1040/910	1250/1040/910	1500/1200/1050	1500/1200/1050	1800/1440/1260	1800/1440/1260	1800/1440/1260
	Noise Level(Hi/Mid/Low)	dB(A)	38/34/30	38/34/30	41/37/34	41/37/34	41/38/35	41/38/35	41/38/35
Dimension (WxDxH)	Net(Body)	mm	835×835×250	835×835×250	835×835×250	835×835×250	835×835×290	835×835×290	835×835×290
	Packing(Body)	mm	910×910×310	910×910×310	910×910×310	910×910×310	910×910×350	910×910×350	910×910×350
	Net(Panel)	mm	950×950×55	950×950×55	950×950×55	950×950×55	950×950×55	950×950×55	950×950×55
	Packing(Panel)	mm	1000×1000×100	1000×1000×100	1000×1000×100	1000×1000×100	1000×1000×100	1000×1000×100	1000×1000×100
Weight	Net/Gross(Body)	kg	27/34	27/34	28/35	28/35	30/37	30/37	30/37
	Net/Gross(Panel)	kg	5/7	5/7	5/7	5/7	5/7	5/7	5/7
Pipe Diameter	Liquid Side	mm(inch)	9.52(3/8)	9.52(3/8)	9.52(3/8)	9.52(3/8)	9.52(3/8)	9.52(3/8)	9.52(3/8)
	Gas Side	mm(inch)	15.88(5/8)	15.88(5/8)	15.88(5/8)	15.88(5/8)	19.05(3/4)	19.05(3/4)	19.05(3/4)
	Drainage	mm(inch)	DN20(R3/4)	DN20(R3/4)	DN20(R3/4)	DN20(R3/4)	DN20(R3/4)	DN20(R3/4)	DN20(R3/4)
Stuffing Quantity		unit	78/168/184	78/168/184	78/168/184	78/168/184	68/150/170	68/150/170	68/150/170

Notes:

1. Cooling Capacity: Indoor temperature 27°C DB/19°C WB; Outdoor temperature: 35°C DB/24°C WB.
2. Heating Capacity: Indoor temperature 20°C DB; Outdoor temperature: 7°C DB/6°C WB.
3. Piping Length: Equivalent piping length: 7.5m, level difference: 0m.
4. Sound level is measured at 1.4m below the unit.
5. The above designs and specifications are subject to change without prior notice. Final specifications please refer to technical specification provided by sales representative.

Enhance any environment with the best of air conditioning performance and sleek style

Toyo-ac Slim 1Way Cassette is an optimized air solution that suits both practical and aesthetic needs with its simple design and efficient cooling operation. The slim, rounded design of the Slim 1Way Cassette unit creates a near-seamless ceiling for a clean ambiance. And its progressive design, including superior blade technology, delivers high performance and easy management without compromise.

Visually appealing panel

Slim 1Way Cassette projects refined simplicity. The clean lines and simple display design make this a modern classic, which looks great with any interior.

Slim and compact design

At a height of only 135 mm, the Slim 1Way Cassette is the world's thinnest indoor air cooling unit. The compact, lightweight design makes installation and maintenance easier than ever with a panel area that's been reduced by 30 percent. And with its high performance and understated elegance, the unit blends seamlessly into interiors of all types and styles.

Enhance any décor with refined elegance and comfort

Sim1Way Cassette features a simple and refined design. The clean lines and simple display design make this a modern classic, which looks great with any interior.

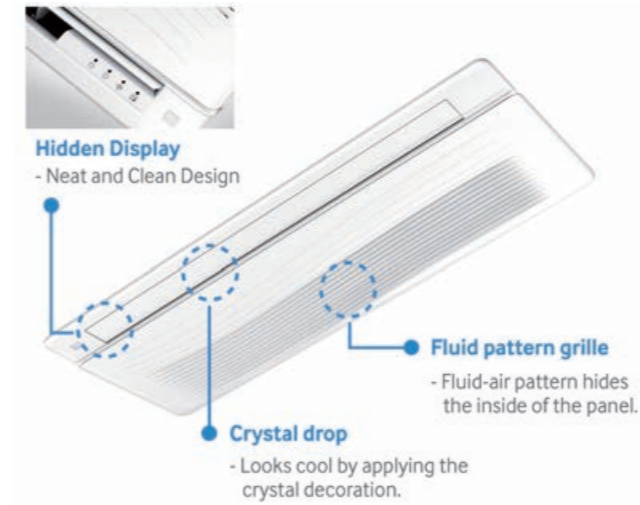

Ease installation and maintenance with a slim and compact design

At a height of only 135mm, the Slim 1Way Cassette is the world's thinnest indoor air cooling unit. The compact, lightweight design makes installation and maintenance in your space easier than ever. These high-performing units are so discreet that they can easily blend into interiors of all types and styles.

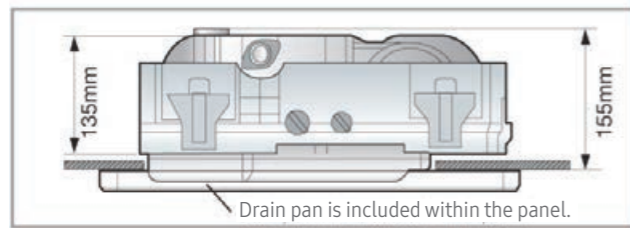

NOTE

Make sure that there is enough installation space. Allow at least 170mm for the installation.



Panel area has been reduced by 30%.



Air reaches every corner of the room.

Blade angle can move from 40°C - 80°C to reach every corner of the room.

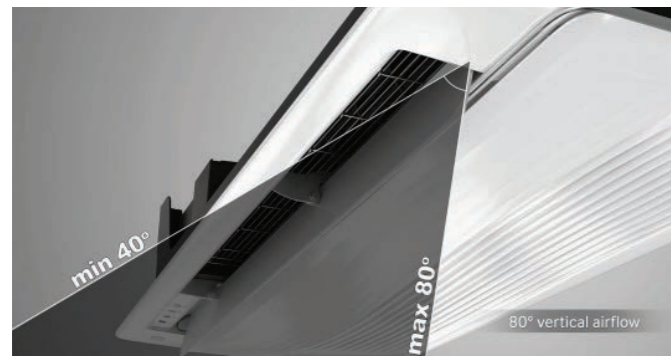

Lighter indoor unit

the first to apply ABS cabinets into its indoor units to provide the lightest units on the market.

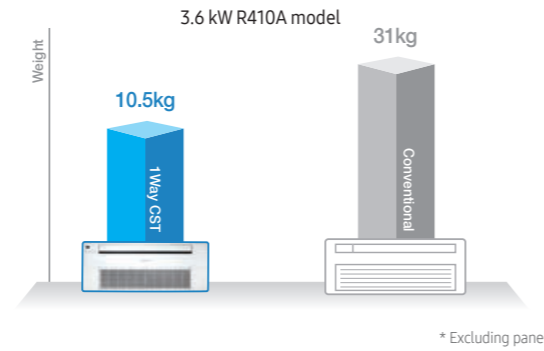

Drip-free operation

The check valve on the drain pump prevents drained water from flowing backward into the drain pan. This minimizes the drain pan's water level, eliminating the hassles of water stagnation or overflowing drain water dripping into the interior.

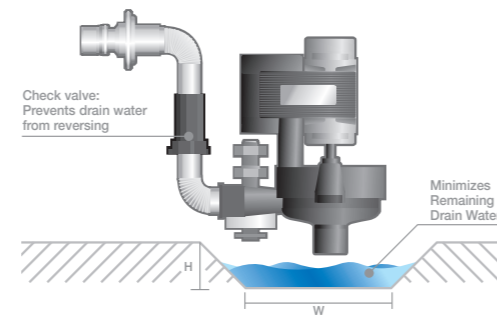

Quiet operation

TOYO's new blade design drastically reduces noise levels so that users can relax in peace and quiet.

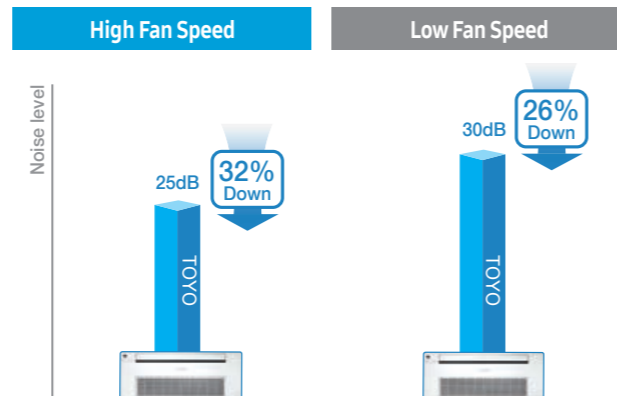

Specification AC 50Hz

Model	Indoor		TVOCH(2.8)4R1	TVOCH(3.6)4R1	TVOCH(4.5)4R1	TVOCH(5.6)4R1	TVOCH(7.1)4R1
Capacity	Cooling	kW	2.8	3.6	4.5	5.6	7.1
	Heating	kW	3.2	4.0	5.0	6.3	8.0
Electric Data	Power Supply	V~,Hz,Ph	220~240,50,1	220~240,50,1	220~240,50,1	220~240,50,1	220~240,50,1
	Rated Power	W	40	40	45	45	50
Performance	Air Flow Volume(Hi/Mid/Low)	m ³ /h	510/410/310	600/480/360	720/570/450	910/830/700	1000/850/750
	Noise Level(Hi/Mid/Low)	dB(A)	36/34/30	38/28/26	42/39/35	45/41/39	47/43/40
Dimension (WxDxH)	Net(Body)	mm	870×460×250	870×460×250	870×460×250	1180×495×290	1180×495×290
	Packing(Body)	mm	1130×570×355	1130×570×355	1130×570×355	1440×660×385	1440×660×385
	Net(Panel)	mm	1070×520×33	1070×520×33	1070×520×33	1380×550×33	1380×550×33
	Packing(Panel)	mm	1085×555×175	1085×555×175	1085×555×175	1400×585×175	1400×585×175
Weight	Net/Gross(Body)	kg	24/31	26/33	26/33	38/45	38/45
	Net/Gross(Panel)	kg	3/5	3/5	3/5	5/7	5/7
Refrigerant Type			R410A	R410A	R410A	R410A	R410A
Pipe Diameter	Liquid Side	mm(inch)	6.35(1/4)	6.35(1/4)	6.35(1/4)	6.35(1/4)	9.52(3/8)
	Gas Side	mm(inch)	12.7(1/2)	12.7(1/2)	12.7(1/2)	12.7(1/2)	15.88(5/8)
Drainage		mm(inch)	R3/4in(DN20)	R3/4in(DN20)	R3/4in(DN20)	R3/4in(DN20)	R3/4in(DN20)
Stuffing Quantity		unit	88/186/210	88/186/210	88/186/210	60/120/123	60/120/123

Notes:

- Cooling Capacity: Indoor temperature 27°C DB/19°C WB; Outdoor temperature: 35°C DB/24°C WB.
- Heating Capacity: Indoor temperature 20°C DB; Outdoor temperature: 7°C DB/6°C WB.
- Piping Length: Equivalent piping length: 7.5m, level difference: 0m.
- Sound level is measured at 1.4m below the unit.
- The above designs and specifications are subject to change without prior notice. Final specifications please refer to technical specification provided by sales representative.

Equip even the narrowest of spaces with high-performance cooling and heating

The 2Way Cassette is perfectly suited for long and narrow places with limited installation space, thanks to its compact, slim frame. The unit distributes airflow from two sides, providing powerful cooling and heating performance in an instant for a pleasant environment.

The 2Way Cassette indoor air conditioning unit delivers optimal airflow and efficiency with features such as:

- **Exceptional operation and control.** Easily maintain a calming, comfortable atmosphere with broad airflow coverage, temperature control and self-diagnosis.
- **Easy, flexible installation.** Reduce the time and effort of installation with a compact size that fits the ceiling space impeccably.



Create a pleasant atmosphere and maintain it effortlessly

The slim build and smart operation of the TOYO 2Way Cassette make it easy to set the ideal indoor climate even in uniquely sized spaces. And maintaining such comfort levels is just as simple with optimum temperature control and self-diagnosis mode.

Long, narrow fit

With its slim and compact size, the 2Way Cassette indoor unit is just the right air solution for long, narrow places such as corridors and classrooms. This unit saves up to 26 percent more space when compared to conventional 4Way cassettes, and melds quietly into the interior design.

Broad coverage

The Twin Cross Flow Fan integrated into 2Way Cassette spreads cool or warm air farther and wider throughout rectangular spaces with less noise.

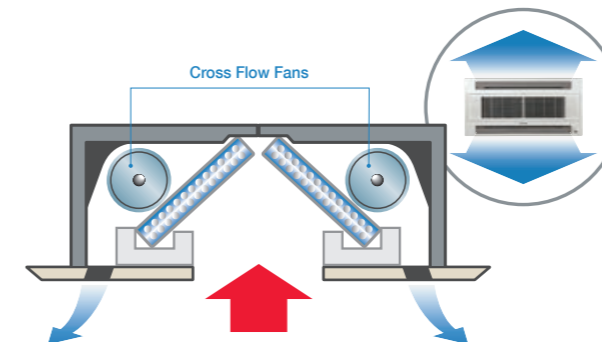

Even airflow distribution

The 2Way Cassette blades swing right and left to evenly distribute cool and warm air to every nook and cranny of the interior, keeping the environment pleasant and comfortable.

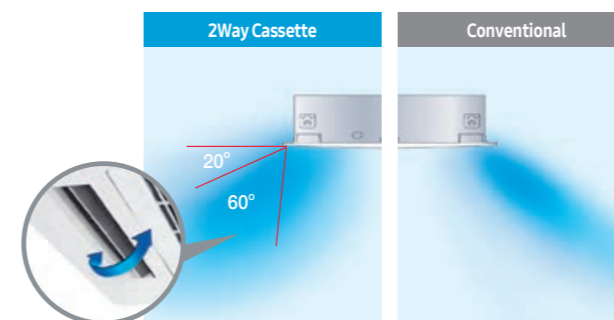

Optimized temperature control

The Optimum Temperature Control function detects and minimizes temperature difference between the top and bottom of the space to maintain an ideal temperature. Users can set the temperature detection option on the indoor unit or with the optional remote controller (MWR-WE10*).

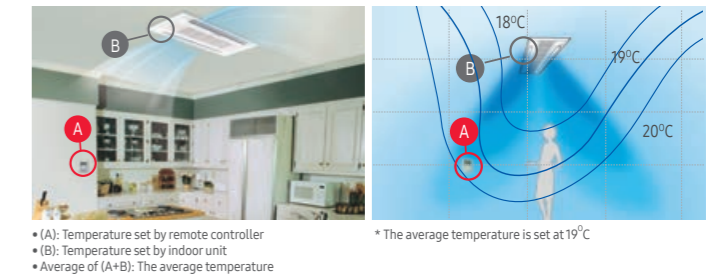

Self-diagnosis mode

In the event of a malfunction, the indoor unit operates the self-diagnosis mode to display an error code indicated by an LED light, enabling users to easily resolve the problem.

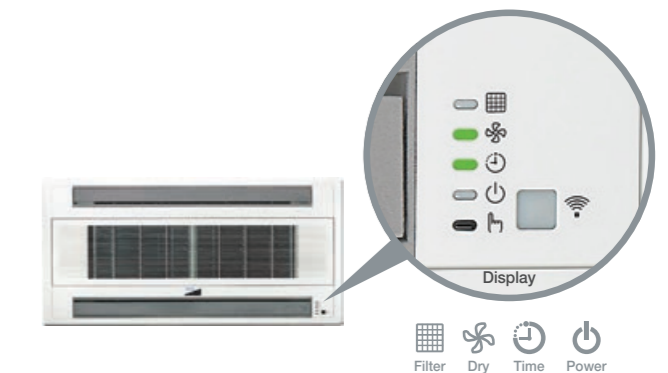

Reduce the hassle of installation with a compact size and adaptable design

The modestly sized 2Way Cassette supports quick, simple setup for the ultimate in convenience, comfort and performance.

Small size, big performance

The 2 Way Cassette indoor unit is now 45 percent smaller than conventional models, making it even easier to incorporate into the building design.

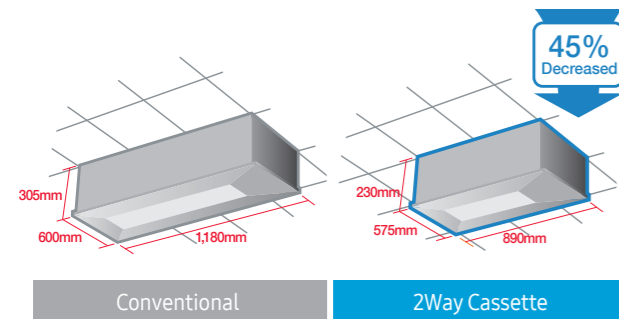

Standardized fit for easy installation

The 2Way Cassette unit dimensions allow for easy installation into standard ceiling grids (600W x 600D) for a tailored fit that blends nearly unnoticeably into the interior framework.

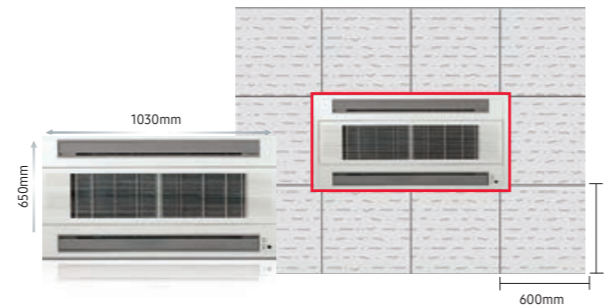

Simple, smart drainage structure

With 750 mm of discharge head, users can install the drain themselves, saving them time and costs.

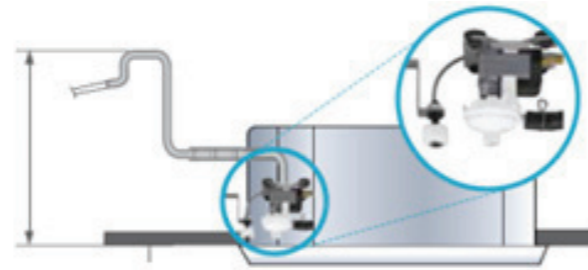

Advanced drain hose

TOYO's 2Way Cassette system air conditioner uses an advanced drain hose, which is recognized in Europe for its easy installation and leak prevention.

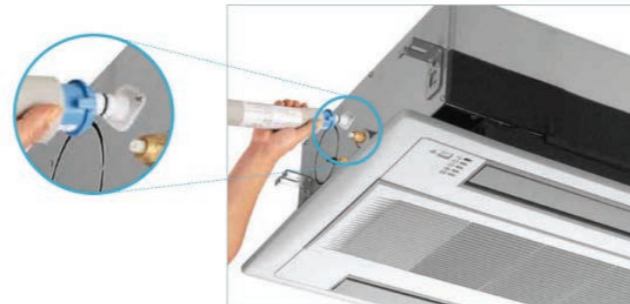

Ultra-light weight

A slim and compact size reduces the setup space needed for easy installation and management.

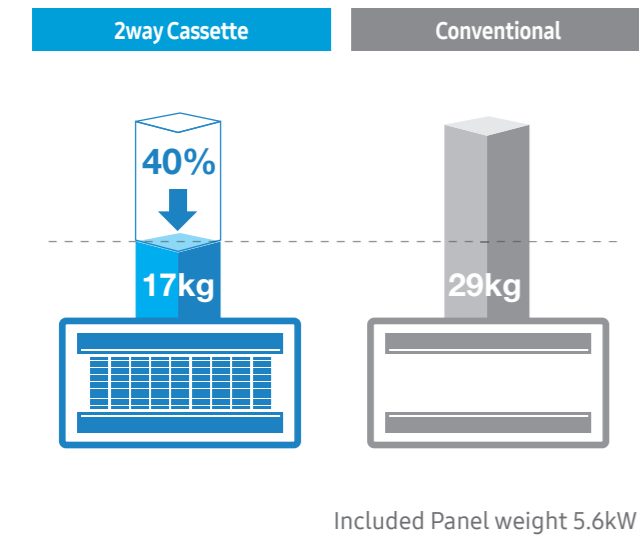

Specification AC 50Hz

Model	Indoor		TVTCH(2.8)4R1	TVTCH(3.6)4R1	TVTCH(4.5)4R1	TVTCH(5.6)4R1	TVTCH(7.1)4R1
Capacity	Cooling	kW	2.8	3.6	4.5	5.6	7.1
	Heating	kW	3.2	4.0	5.0	6.3	8.0
Electric Data	Power Supply	V~,Hz,Ph	220~240,50,1	220~240,50,1	220~240,50,1	220~240,50,1	220~240,50,1
	Rated Power	W	60	62	68	85	94
Performance	Air Flow Volume(Hi/Mid/Low)	m ³ /h	500/426/376	616/523/462	773/657/310	900/765/657	1165/990/873
	Noise Level(Hi/Mid/Low)	dB(A)	37/31/25	39/36/32	43/37/31	45/41/39	47/43/40
Dimension (WxDxH)	Net(Body)	mm	960x520x315	960x520x315	960x520x315	1200x520x315	1200x520x315
	Packing(Body)	mm	1265x685x395	1265x685x395	1265x685x395	1506x685x395	1506x685x395
	Net(Panel)	mm	1203x630x33	1203x630x33	1203x630x33	1443x630x33	1443x630x33
	Packing(Panel)	mm	1220x665x175	1220x665x175	1220x665x175	1460x665x175	1460x665x175
Weight	Net/Gross(Body)	kg	32/39	32/39	37/44	37/44	40/47
	Net/Gross(Panel)	kg	4.5/6.5	4.5/6.5	5/7	5/7	7.5/9.5
Refrigerant Type			R410a	R410a	R410a	R410a	R410a
Pipe Diameter	Liquid Side	mm(inch)	6.35(1/4)	6.35(1/4)	6.35(1/4)	9.52(3/8)	9.52(3/8)
	Gas Side	mm(inch)	12.7(1/2)	12.7(1/2)	12.7(1/2)	15.88(5/8)	15.88(5/8)
	Drainage	mm(inch)	R3/4in(DN20)	R3/4in(DN20)	R3/4in(DN20)	R3/4in(DN20)	R3/4in(DN20)
Stuffing Quantity	20/40/40H	unit	56/116/135	56/116/135	56/116/135	54/102/117	54/102/117

Notes:

1. Cooling Capacity: Indoor temperature 27°C DB/19°C WB; Outdoor temperature: 35°C DB/24°C WB.
2. Heating Capacity: Indoor temperature 20°C DB; Outdoor temperature: 7°C DB/6°C WB.
3. Piping Length: Equivalent piping length: 7.5m, level difference: 0m.
4. Sound level is measured at 1.4m below the unit.
5. The above designs and specifications are subject to change without prior notice. Final specifications please refer to technical specification provided by sales representative.

Overview

The Ducted Type air conditioning units are a smart solution for low-maintenance, consistent cooling and heating performance in any environment. Their compact, slim frame blends seamlessly into ceilings, enhancing the beauty of the interior space and affording users more flexible installation options.

Various ducted air solutions

Offering a comprehensive lineup, TOYO Ducted type air conditioning units offer just the right solution for every need:

- **Duct S.** This solution features 3way service, automatic air volume, light weight and high EER.
- **Slim Duct.** This solution is a low static pressure model, which is optimized for places such as hotels and residences.
- **Middle Static Pressure (MSP).** This model is specifically designed to enhance interior design for large spaces such as offices, stores, or residences.
- **High Static Pressure (HSP).** This model is optimized for large spaces or places.
- **AHu Fresh Air type.** This model is ideal for places such as restaurant kitchens, where 100% fresh air supply is needed.

Smart pressure control

The Ducted Type units feature a smart pressure control system. This system adjusts the fan speed based on the external static pressure (ESP), delivering consistent cooling and heating power, regardless of the surrounding environment.

Convenient installation

The optional lift-up drain pump lifts condensed water up to 750 mm, compared to a limit of 700 mm on conventional models, for flexible and convenient installation.

Experience performance and convenient comfort for any weather condition

The Duct S delivers unparalleled cooling and heating and flexible management with customizable comfort settings in any climate—all year round. Plus, it boasts a slim, compact size and multiple access points for easy setup exactly where needed.

The Duct S indoor air conditioning unit delivers smooth, consistent operation and convenience with features such as:

- **Efficient operation.** Stage the desired atmosphere with energy-efficient performance and customized airflow.
- **Smart management.** Cool spaces efficiently and manage the air conditioning unit even while away, with features designed for efficiency and control.
- **Easy, flexible setup.** Install and maintain even multiple units with a compact and easily accessible design.

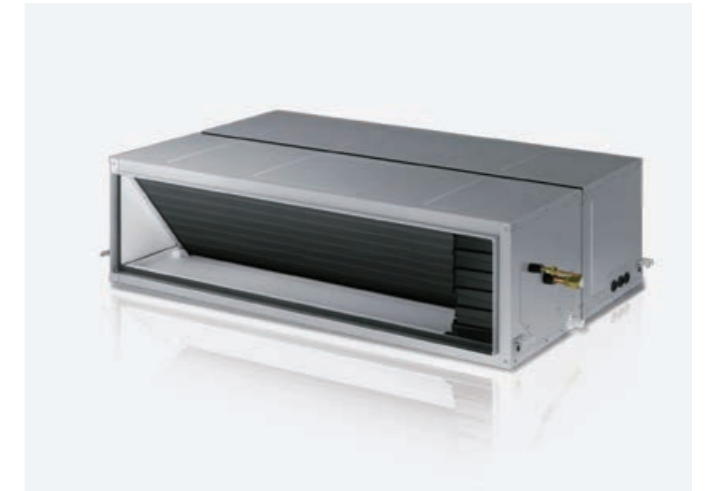

Deliver consistent cooling and heating with innovative operation for maximum comfort

Duct S is a global frontrunner in energy-efficient design, temperature control and power. Its aerodynamic blade technology increases airflow silently while adjustable air tuning customizes the indoor climate for any situation.

World-class energy efficiency

The Duct S unit boasts cutting-edge technologies to deliver stellar energy efficiency.

- **Twin Rotary Compressors.** These robust compressors reduce fluctuation and vibration by 75 percent for effective reluctance.
- **FME/FMC (Flat Micro-channel Evaporator/Condenser).** FME/FMC technology achieves a 30 percent increase in efficiency compared with the conventional fin and tube type. It has also enabled a 30 percent decrease in unit size.

Silent performance

The Duct S includes aerodynamic blades that increase air volume by 10 percent with less noise for powerful comfort with less distraction.

Easy air tuning

Smart Tuning provides the delicate control needed for optimum comfort for any occasion. Users can easily fine-tune operational power to suit their activity level, while also ensuring minimum noise and energy savings.

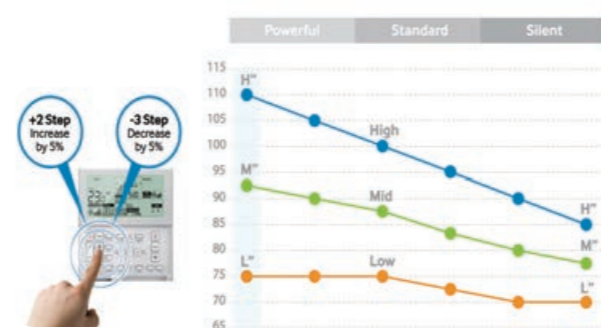

Automatic air volume

Duct S features ingenious technology that senses the current air volume and pressure and then quickly adjusts its performance to ensure optimum comfort, whatever the duct length.

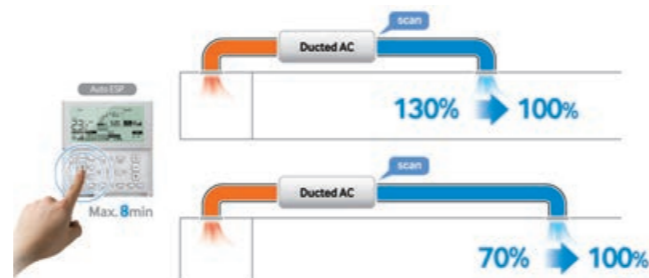

Powerful cooling

With the integration of the all new sirocco fan, the Duct S ensures sufficient air volume by adopting a bigger, more powerful fan than conventional models.

Cleaner, healthier air

Users can clean indoor air with the optional Virus Doctor for a cleaner work or living atmosphere. The easy-to-install Virus Doctor generates active hydrogen and oxygen ions to eliminate airborne contaminants, completely eradicate airborne bacteria and allergens, and even neutralize OH (hydroxyl) radicals.

Minimize maintenance with innovative management and anywhere control

Duct S offers smart management features and settings that enable users to spend less time maintaining the unit and more time on what matters most to them. Users can enjoy stress-free comfort and control all year and all day long.

Intuitive zone control

With the Duct S Zone Controller, users can cool multiple spaces easily while conserving energy. Up to eight zones can be connected and controlled by a single indoor unit. This function enables users to create the perfect ambiance in different rooms and reduce power consumption by turning the dampers on and off. All this control is wielded easily from a stylish, wide touchscreen that supports intuitive and simple operation.

All-season comfort

Away Mode enables users to maintain comfort and energy savings with thermal storage operation to keep the room cool during the summer season and warm during winter.

Anytime temperature control

The Duct S enables users to have separate settings for daytime and nighttime, so they can live and sleep in perfect comfort.

Three-step quiet performance

Ensure quiet operation during the night with a reduced noise level of 3-7 dB. Duct S minimizes noise levels with 3-step quiet operation—1 step: 3 dB; 2 step: 5 dB; 3 step: 7 dB.

Agile, anywhere operation

With optional Smart Wi-Fi, users can control their AC anywhere, anytime using a smart device, and turn it off easily to conserve energy, even while away from home.

EZ Filter, easy maintenance

The Duct S includes a filter that is easy to assemble and disassemble. And filter cleanup and maintenance are hassle-free—simply rinse the filter under running water.



Streamline management with a flexible design

The Duct S is designed especially for simple installation, handling and maintenance. Its discreet, accessible design makes for easy upkeep, while the smart plug-and-connect drainage streamlines maintenance for even multiple units.

Slim design and light weight

A streamlined construction makes the Duct S convenient to install and maintain in any building. Its compact, slender design reduces its volume and weight compared to conventional air conditioners. Duct S is 30 percent smaller than its counterparts, so it fits easily into small spaces. But despite its small frame, Duct S offers exceptional efficiency, while its light weight supports convenient handling and setup.

Wide range of ESP

Users can choose from a complete range of Duct S products to deliver the right capacity, right ESP and right sized product.

Three-way access

With its smart, multi-entry design and slide fit, users can access the Duct S from three directions (top, side and bottom) for easy maintenance.

Plug-and-connect drainage

The optional Plug and Connect External Type drain pump takes the hassle out of draining the unit. Simply plug it in and connect it, and with the single drain pump, maintaining all the building's Duct S units is easier than ever. Plus, the advanced check valve prevents drain water backflow, freeing the unit from the bacteria and fungi of water stagnation in the drain pan.



From the Top



From the Bottom

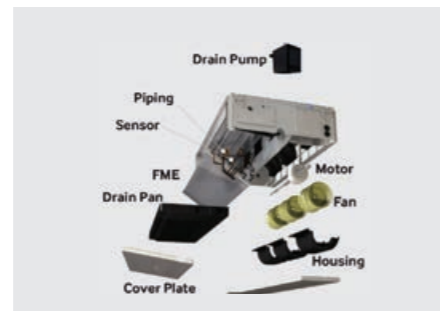

From the Side



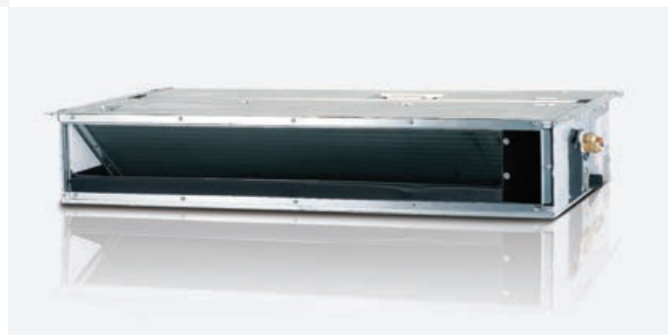

Temper any environment with industry-best lightweight design and optimized airflow

The new TOYO Slim Duct visually blends into the ceiling while providing powerful cool and warm airflow. It's also easy to install and maintain in any interior regardless of the surrounding environment with its compact size and weight—the lightest in the industry.

Flexible setup

The air inlet can be set up either on the bottom or rear of the unit, giving users greater flexibility in installation.

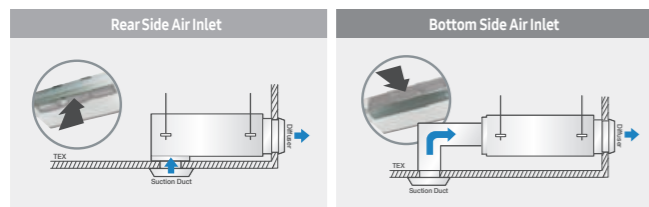

Simple drain pump installation

The new drain pump in the Slim Duct unit can be installed from the side by simply removing the right side panel. Users no longer need to disassemble the top cover to install, check or repair the drain pump for maximum convenience.

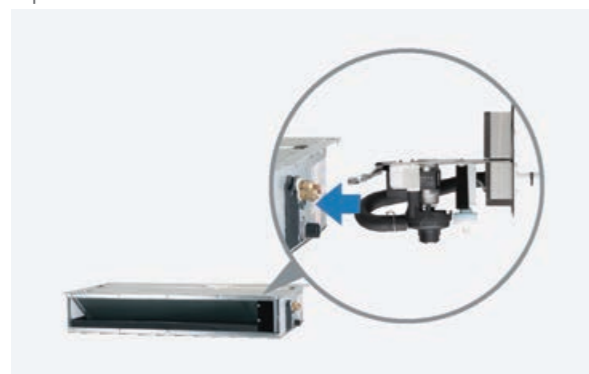

Various installation options

Slim Duct S adopts an ultra-compact, slim size with its thin width, which is 200 mm narrower than conventional products. This slender build enables flexible installation and maintenance in various environments.

World's lightest weight

The efficient Slim Duct S is the lightest duct air conditioning unit on the market. At a weight that's 15 percent lighter than conventional units, Slim Duct S offers the best in convenient installation and maintenance.

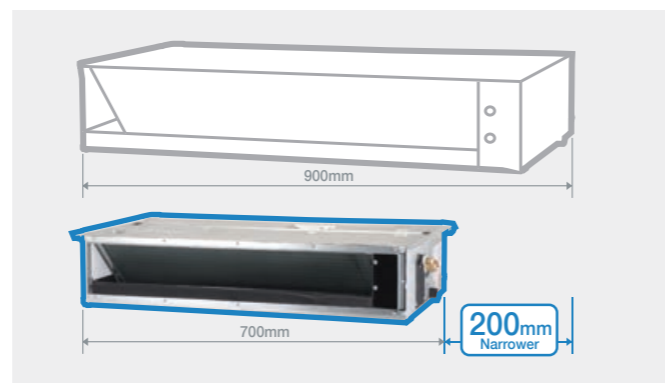

Easy access, easy maintenance

Slim Duct features a flexible design that enables users to easily access its parts to maintain the unit.

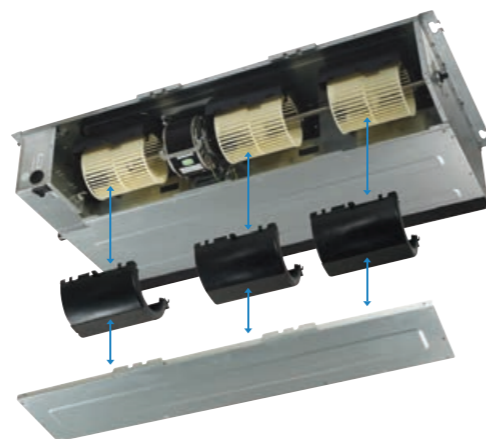

Model	Indoor		TVSDH(2.2)4R1	TVSDH(2.8)4R1	TVSDH(3.6)4R1	TVSDH(4.5)4R1	TVSDH(5.6)4R1	TVSDH(7.1)4R1
Capacity	Cooling	kW	2.2	2.8	3.6	4.5	5.6	7.1
	Heating	kW	2.5	3.0	4.3	5.0	6.0	8.0
Electric Data	Power Supply	V~,Hz,Ph	220~240,50,1	220~240,50,1	220~240,50,1	220~240,50,1	220~240,50,1	220~240,50,1
	Rated Power	W	45	45	75	137	137	187
Performance	Air Flow Volume(Hi/Mid/Low)	m ³ /h	420/336/294	420/336/294	580/464/406	860/688/602	860/688/602	1200/960/840
	Noise Level(Hi/Mid/Low)	dB(A)	36/33/30	36/33/30	38/35/32	40/37/34	40/37/34	42/39/36
	External Static Pressure(ESP)	Pa	12/30	12/30	12/30	12/30	12/30	12/30
Dimension(WxDxH)	Net	mm	880x547x240	880x547x240	880x547x240	1110x547x240	1110x547x240	1305x547x240
	Packing	mm	980x620x280	980x620x280	980x620x280	1210x620x280	1210x620x280	1400x620x280
Weight	Net	kg	22.5	22.5	22.5	31	31	35.5
	Gross	kg	26	26	26	35	35	40.5
Refrigerant Type			R410a	R410a	R410a	R410a	R410a	R410a
Pipe Diameter	Liquid Side	mm	6.35	6.35	6.35	6.35	6.35	9.52
	Gas Side	mm	9.52	9.52	12.7	12.7	12.7	15.88
	Drainage	mm	R3/4in(DN20)	R3/4in(DN20)	R3/4in(DN20)	R3/4in(DN20)	R3/4in(DN20)	R3/4in(DN20)
Stuffing Quantity	20/40/40H	unit	176/364/414	176/364/414	176/364/414	133/281/333	133/281/333	123/253/289

Model	Indoor		TVSDH(2.2)2R1	TVSDH(2.8)2R1	TVSDH(3.6)2R1	TVSDH(4.5)2R1	TVSDH(5.6)2R1	TVSDH(7.1)2R1
Capacity	Cooling	kW	2.2	2.8	3.6	4.5	5.6	7.1
	Heating	kW	2.5	3.0	4.3	5.0	6.0	8.0
Electric Data	Power Supply	V~,Hz,Ph	208~230,60,1	208~230,60,1	208~230,60,1	208~230,60,1	208~230,60,1	208~230,60,1
	Rated Power	W	54	54	90	164	164	224
Performance	Air Flow Volume(Hi/Mid/Low)	m ³ /h	420/336/294	420/336/294	580/464/406	860/688/602	860/688/602	1200/960/840
	Noise Level(Hi/Mid/Low)	dB(A)	36/33/30	36/33/30	38/35/32	40/37/34	40/37/34	42/39/36
	External Static Pressure(ESP)	Pa	12/30	12/30	12/30	12/30	12/30	12/30
Dimension(WxDxH)	Net	mm	880x547x240	880x547x240	880x547x240	1110x547x240	1110x547x240	1305x547x240
	Packing	mm	980x620x280	980x620x280	980x620x280	1210x620x280	1210x620x280	1400x620x280
Weight	Net	kg	22.5	22.5	22.5	31	31	35.5
	Gross	kg	26	26	26	35	35	40.5
Refrigerant Type			R410a	R410a	R410a	R410a	R410a	R410a
Pipe Diameter	Liquid Side	mm	6.35	6.35	6.35	6.35	6.35	9.52
	Gas Side	mm	9.52	9.52	12.7	12.7	12.7	15.88
	Drainage	mm	R3/4in(DN20)	R3/4in(DN20)	R3/4in(DN20)	R3/4in(DN20)	R3/4in(DN20)	R3/4in(DN20)
Stuffing Quantity	20/40/40H	unit	176/364/414	176/364/414	176/364/414	133/281/333	133/281/333	133/281/333

★ Remark: The above designs and specifications are subject to change of product improvement without prior notice.

Mid ESP Duct



Deliver increased airflow to broader areas with quiet, powerful cooling and heating



Concealed behind the ceiling, TOYO MSP Duct provides powerful yet silent operation with external static pressure control. Its exceptional static pressure enables a broad coverage area and provides stable, efficient performance in larger spaces.

Extensive coverage

MSP Duct offers greater static pressure than most slim ducts. This higher pressure level enables users to design more inlets and outlets with longer ductwork to provide even more airflow to larger areas.

Quiet performance

The external static pressure control makes it easy to customize the ductwork to ensure efficiency and silent operation.

Easy upkeep and installation

The MSP Duct unit features quickly accessible parts so users can maintain the unit with ease. And its compact size and narrow width of 900 mm enable flexible installation and management for added user convenience.

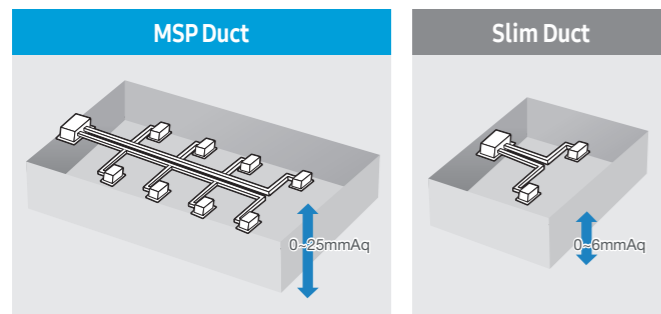
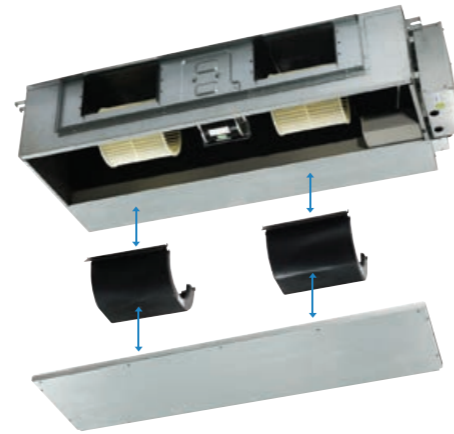

Specification-DC fan motor

Model	Indoor		TVMDH(4.5)4R1	TVMDH(5.6)4R1	TVMDH(7.1)4R1	TVMDH(8)4R1	TVMDH(9)4R1
Capacity	Cooling	kW	4.5	5.6	7.1	8.0	9.0
	Heating	kW	5.1	6.3	8.0	9.0	10.0
Electric Data	Power Supply	V~, Hz, Ph	220~240, 50/60, 1	220~240, 50/60, 1	220~240, 50/60, 1	220~240, 50/60, 1	220~240, 50/60, 1
	Rated Power	W	73	73	106	106	126
Performance	Air Flow Volume(Hi/Mid/Low)	m ³ /h	950/850/700	950/850/700	1300/1100/850	1300/1100/850	1400/1200/950
	Noise Level(Hi/Mid/Low)	dB(A)	40/37/33	40/37/33	41/39/36	41/39/36	44/41/39
	External Static Pressure(ESP)	Pa	50/80	50/80	50/80	50/80	50/80
Dimension (WxDxH)	Net	mm	890×735×290	890×735×290	890×735×290	890×735×290	890×735×290
	Packing	mm	1070×800×360	1070×800×360	1070×800×360	1070×800×360	1070×800×360
Weight	Net/Gross	kg	29.5/34	29.5/34	30.5/35	30.5/35	32.5/37
	Liquid Side	mm(inch)	6.35(1/4)	6.35(1/4)	9.52(3/8)	9.52(3/8)	9.52(3/8)
Pipe Diameter	Gas Side	mm(inch)	12.7(1/2)	12.7(1/2)	15.88(5/8)	15.88(5/8)	15.88(5/8)
	Drainage	mm(inch)	DN20(R3/4)	DN20(R3/4)	DN20(R3/4)	DN20(R3/4)	DN20(R3/4)
Stuffing Quantity	20/40/40H	unit	84/180/210	84/180/210	84/180/210	84/180/210	84/180/210

Specification-DC fan motor

Model	Indoor		TVMDH(10)4R1	TVMDH(11.2)4R1	TVMDH(12.5)4R1	TVMDH(14)4R1	TVMDH(15)4R1
Capacity	Cooling	kW	10.0	11.2	12.5	14.0	15.0
	Heating	kW	11.2	12.5	14.0	15.0	17.0
Electric Data	Power Supply	V~, Hz, Ph	220~240, 50/60, 1	220~240, 50/60, 1	220~240, 50/60, 1	220~240, 50/60, 1	220~240, 50/60, 1
	Rated Power	W	126	191	191	220	220
Performance	Air Flow Volume(Hi/Mid/Low)	m ³ /h	1400/1200/950	2000/1700/1400	2000/1700/1400	2200/1850/1550	2200/1850/1550
	Noise Level(Hi/Mid/Low)	dB(A)	44/41/39	45/42/39	45/42/39	47/43/41	47/43/41
	External Static Pressure(ESP)	Pa	50/80	50/80	50/80	50/80	50/80
Dimension (WxDxH)	Net	mm	890×735×290	1250×735×290	1250×735×290	1250×735×290	1250×735×290
	Packing	mm	1070×800×360	1430×800×360	1430×800×360	1430×800×360	1430×800×360
Weight	Net/Gross	kg	32.5/37	42/47	42/47	42/47	42/47
	Liquid Side	mm(inch)	9.52(3/8)	9.52(3/8)	9.52(3/8)	9.52(3/8)	9.52(3/8)
Pipe Diameter	Gas Side	mm(inch)	15.88(5/8)	15.88(5/8)	15.88(5/8)	15.88(5/8)	15.88(5/8)
	Drainage	mm(inch)	DN20(R3/4)	DN20(R3/4)	DN20(R3/4)	DN20(R3/4)	DN20(R3/4)
Stuffing Quantity	20/40/40H	unit	84/180/210	66/138/161	66/138/161	66/138/161	66/138/161

Specification-50Hz AC fan motor

Model	Indoor		TVMDH(4.5)4R1	TVMDH(5.6)4R1	TVMDH(7.1)4R1	TVMDH(8)4R1	TVMDH(9)4R1
Capacity	Cooling	kW	4.5	5.6	7.1	8.0	9.0
	Heating	kW	5.0	6.0	8.0	10.0	11.0
Electric Data	Power Supply	V~, Hz, Ph	220~240, 50, 1	220~240, 50, 1	220~240, 50, 1	220~240, 50, 1	220~240, 50, 1
	Rated Power	W	100	100	160	160	160
Performance	Air Flow Volume(Hi/Mid/Low)	m ³ /h	950/850/700	950/850/700	1300/1100/850	1300/1100/850	1400/1200/950
	Noise Level(Hi/Mid/Low)	dB(A)	40/37/33	40/37/33	41/39/36	41/39/36	44/41/39
	External Static Pressure(ESP)	Pa	50/80	50/80	50/80	50/80	50/80
Dimension (WxDxH)	Net	mm	890×735×290	890×735×290	890×735×290	890×735×290	890×735×290
	Packing	mm	1070×800×360	1070×800×360	1070×800×360	1070×800×360	1070×800×360
Weight	Net/Gross	kg	29.5/34	29.5/34	30.5/35	30.5/35	32.5/37
	Liquid Side	mm(inch)	6.35(1/4)	6.35(1/4)	9.52(3/8)	9.52(3/8)	9.52(3/8)
Pipe Diameter	Gas Side	mm(inch)	12.7(1/2)	12.7(1/2)	15.88(5/8)	15.88(5/8)	15.88(5/8)
	Drainage	mm(inch)	DN20(R3/4)	DN20(R3/4)	DN20(R3/4)	DN20(R3/4)	DN20(R3/4)
Stuffing Quantity	20/40/40H	unit	84/180/210	84/180/210	84/180/210	84/180/210	84/180/210

Notes:

1. Cooling Capacity: Indoor temperature 27°C DB/ 19°C WB; Outdoor temperature: 35°C DB/ 24°C WB.
2. Heating Capacity: Indoor temperature 20°C DB; Outdoor temperature: 7°C DB/ 6°C WB.
3. Piping Length: Equivalent piping length: 7.5m, level difference: 0m.
4. Sound level is measured at 1.4m below the unit.
5. The above designs and specifications are subject to change without prior notice. Final specifications please refer to technical specification provided by sales representative.

Control the atmosphere effortlessly with robust, adaptable performance

With the capacity to handle high external static pressure up to 25 mmAq, the powerful TOYO HSP Duct provides an expansive coverage area with outstanding cooling and heating performance. HSP Duct is an ideal fit for spaces with high ceilings and can be flexibly installed to suit various environments.



Silent operation

The external static pressure control makes it easy to customize the ductwork to ensure efficiency and silent operation.

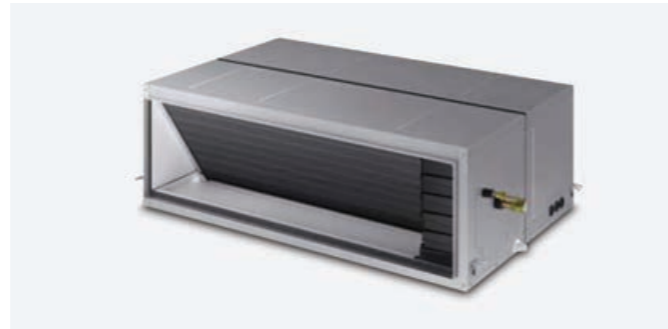

Split fan and coil

Products that are difficult to install are often challenging to use as well. Considering users' product experience from start to finish, TOYO separated the Duct S (AC6000) into two parts, coil and fan, for easier installation and management. When users experience difficulty handling the product due to space limitations or weight, they can install the parts separately and then put them back together as one unit.



Truss chamfer (optional)

The believes that products should improve users' quality of life, not to impose more limitations. By making a small change to the product, users now can install the Duct S (AC6000) right next to the roof's edge, freeing up rooftop space for other purposes.

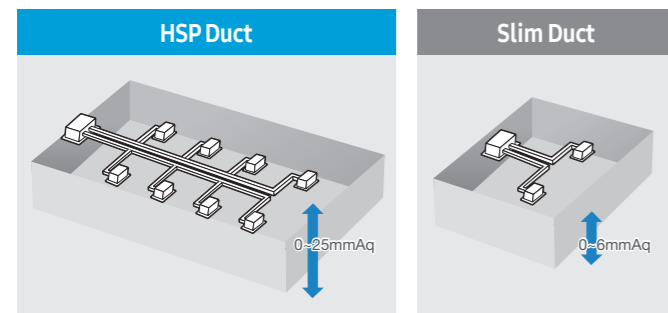
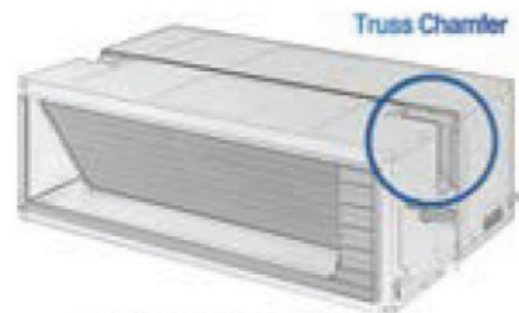

Specification-50Hz AC fan motor

Model	Indoor		TVMDH(11.2)4R1	TVMDH(12.5)4R1	TVMDH(14)4R1	TVMDH(15)4R1	TVMDH(22.4)4R1	TVMDH(28)4R1	TVMDH(45)4R1	TVMDH(56)4R1
Capacity	Cooling	kW	11.2	12.5	14.0	15.0	22.4	28.0	45.0	56.0
	Heating	kW	12.8	13.3	15.0	16.0	25.0	31.5	49.5	61.5
Electric Data	Power Supply	V-, Hz, Ph	220~240, 50, 1	220~240, 50, 1	220~240, 50, 1	220~240, 50, 1	220~240, 50, 1	220~240, 50, 1	380~415, 50, 3	380~415, 50, 3
	Rated Power	W	600	600	600	600	1250	1250	2220	2220
Performance	Air Flow Volume(Hi/Mid/Low)	m ³ /h	2000/1600/1400	2000/1600/1400	2000/1600/1400	2000/1600/1400	4000/3200/2600	4000/3200/2600	8000	8000
	Noise Level(Hi/Mid/Low)	dB(A)	60/57/51	60/57/51	60/57/51	60/57/51	55	55	63	63
	External Static Pressure(ESP)	Pa	196	196	196	196	220	220	200	200
Dimension (WxDxH)	Net	mm	1200×719×380	1200×719×380	1200×719×380	1200×719×380	1350×700×460	1350×700×460	2115×990×855	2115×990×855
	Packing	mm	1235×760×415	1235×760×415	1235×760×415	1235×760×415	1540×810×610	1540×810×610	2225×1025×1015	2225×1025×1015
Weight	Net/Gross	kg	56/59	56/59	56/59	56/59	91/110	91/110	225/260	225/260
	Liquid Side	mm(inch)	9.52(3/8)	9.52(3/8)	9.52(3/8)	9.52(3/8)	12.7(1/2)	12.7(1/2)	12.7(1/2)x2	12.7(1/2)x2
Pipe Diameter	Gas Side	mm(inch)	19.05(3/4)	19.05(3/4)	19.05(3/4)	19.05(3/4)	22.2(7/8)	22.2(7/8)	22.2(7/8)x2	22.2(7/8)x2
	Drainage	mm	DN20(R3/4)	DN20(R3/4)	DN20(R3/4)	DN20(R3/4)	DN25	DN25	DN25	DN25
Stuffing Quantity	20/40/40H	unit	65/140/168	65/140/168	65/140/168	65/140/168	30/63/84	30/63/84	10/22/22	10/22/22

Notes:

1. Cooling Capacity: Indoor temperature 27°C DB/19°C WB; Outdoor temperature: 35°C DB/ 24°C WB.
2. Heating Capacity: Indoor temperature 20°C DB; Outdoor temperature: 7°C DB/ 6°C WB.
3. Piping Length: Equivalent piping length: 7.5m, l level difference: 0m.
4. Sound level is measured at 1.4m below the unit.
5. The above designs and specifications are subject to change without prior notice. Final specifications please refer to technical specification provided by sales representative.

Conserve energy and costs with practical, high-powered operation

Toyo-ac new Outdoor Air Processing Duct is an outside fresh air treatment unit with integrated ventilation, combining fresh air processing and air conditioning via a single system.

Air conditioning indoor units and an Outdoor Air Processing unit can be connected to the same refrigerant line, resulting in enhanced design flexibility and a significant reduction in total system costs. A motor extends the savings with considerably less energy consumption.

High-efficiency motor

The motor supports the highest efficiency level possible. Its low-consumption design saves up to 32 percent more energy than conventional products for more economical and practical operation.

Quiet operation

Equipped with the proficient motor, Outdoor Air Processing Duct operates quietly with a sound level as low as 42 dB, slightly higher than that of a library. Such distraction-free operation ensures optimum comfort and calm for any environment.



Full-range temperature processing

The Outdoor Air Processing Duct supplies fresh air to the interior environment by cold or heat processing a wide spectrum of outside temperatures ranging from -5°C - 52°C.

Flexible installation

This light and compact unit, with its shorter height of 390 mm, enables users to conveniently install and manage it in a variety of areas with a host of installation options.

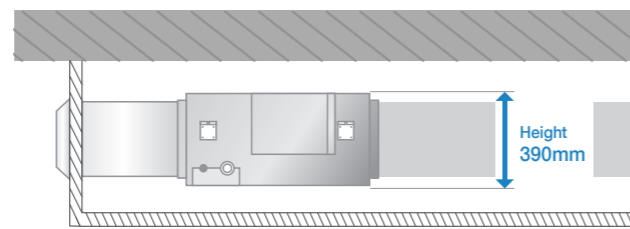

Flexible static pressure control

If the installation area of the duct exceeds the standard, then the static pressure control system maintains the optimized air volume by adjusting the fan speed.

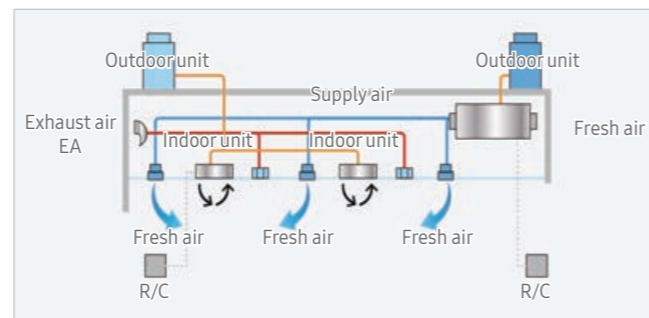

Specification-50Hz AC fan motor

Model	Indoor		TVMDH(22.4)4R1	TVMDH(28)4R1	TVMDH(45)4R1	TVMDH(56)4R1
Capacity	Cooling	kW	22.4	28.0	45.0	56.0
	Heating	kW	18.0	22.0	49.5	61.5
Electric Data	Power Supply	V~,Hz,Ph	220~240,50,1	220~240,50,1	380~415,50,3	380~415,50,3
	Rated Power	W	1000	1000	1520	1520
Performance	Air Flow Volume(Hi/Mid/Low)	m ³ /h	3200	3200	4000	5000
	Noise Level(Hi/Mid/Low)	dB(A)	55	55	57	59
	External Static Pressure(ESP)	Pa	220	220	220	220
Dimension (WxDxH)	Net	mm	1350×700×460	1350×700×460	1820×990×855	2115×990×855
	Packing	mm	1540×810×610	1540×810×610	1935×1025×1015	2225×1025×1015
Weight	Net/Gross	kg	91/110	91/110	150/170	225/255
	Liquid Side	mm(inch)	12.7(1/2)	12.7(1/2)	12.7(1/2)x2	12.7(1/2)x2
Pipe Diameter	Gas Side	mm(inch)	22.2(7/8)	22.2(7/8)	22.2(7/8)x2	22.2(7/8)x2
	Drainage	mm	DN25	DN25	DN25	DN25
Stuffing Quantity	20/40/40H	unit	30/63/84	30/63/84	10/22/22	10/22/22

Notes:

1.Cooling Capacity: Outdoor temperature 35°C DB/24°C WB.

2.Heating Capacity: Outdoor temperature 7°C DB/6°C WB.

3.Piping Length: Equivalent piping length: 7.5m, level difference: 0m.

4.Sound level is measured at 1.4m below the unit.

5.The above design and specifications are subject to change without prior notice. Final specifications please refer to technical specification provided by sales representative.

Connection Conditions:

When only outdoor-air processing units are connected, the total capacity of the outdoor-air processing units must be within 50%~100% of the outdoor units.

When outdoor-air processing units and other type indoor units are connected, the total capacity of the outdoor-air processing units must not exceed 30% of the outdoor units.

Breathe easily with wall-mounted systems designed for all-day freshness

Wall Mount Type air conditioners have been designed from the ground up to be exceptionally efficient. With their stylish, innovative designs, these wall-mounted air conditioners optimize comfort with cool, clean, healthy freshness for everyday living.

Improved blade operation

Wide twin blade can open up to 90° for more effective cooling. The longer twin blade ensures that air reaches every corner of the room with greater control.

Superior dust filtration

A Full High Density (HD) filter creates cleaner air through enhanced filtration, reducing microscopic dust particles by up to 90 percent.

Cleaner, healthier air

Virus Doctor eliminates the harmful substances and viruses breeding in the atmosphere of living spaces, thus providing the highest level of indoor air quality. This smart solution creates a purified zone, eliminating the hazards of airborne allergens and controlling the active oxygen that contributes to disease, cancer and accelerated aging.

Good's sleep

Wall Mount Type units feature Good's sleep mode for a comfortable bedroom climate perfectly tempered for a restful night. With automatic temperature and moisture adjustment, all three vital stages of sleep are protected from humidity and heat so users wake up fully rested and refreshed.



		50Hz						
Model	Indoor		TVWMH(2.2)4R1	TVWMH(2.8)4R1	TVWMH(3.6)4R1	TVWMH(4.5)4R1	TVWMH(5.6)4R1	TVWMH(7.1)4R1
Capacity	Cooling	kW	2.2	2.8	3.6	4.5	5.6	7.1
	Heating	kW	2.5	3.0	4.3	5.0	6.0	8.0
Electric Data	Power Supply	V~,Hz,Ph	220~240,50,1	220~240,50,1	220~240,50,1	220~240,50,1	220~240,50,1	220~240,50,1
	Rated Power	W	60	60	60	80	80	137
Performance	Air Flow Volume(Hi/Mid/Low)	m ³ /h	620/496/434	620/496/434	620/496/434	950/760/665	950/760/665	1100/880/770
	Noise Level(Hi/Mid/Low)	dB(A)	38/35/31	38/35/31	38/35/31	41/38/34	41/38/34	45/42/37
Dimension(WxDxH)	Net	mm	880x286x203	880x286x203	880x286x203	1095x312x215	1095x312x215	1310x322x240
	Packing	mm	950x350x270	950x350x270	950x350x270	1175x375x275	1175x375x275	1420x440x380
Weight	Net	kg	12	12	12	14	14	20
	Gross	kg	14	14	14	17	17	23
Refrigerant Type			R410a	R410a	R410a	R410a	R410a	R410a
Pipe Diameter	Liquid Side	mm	6.35	6.35	6.35	6.35	6.35	9.52
	Gas Side	mm	9.52	9.52	9.52	12.7	12.7	5.88
	Drainage	mm	R3/4in(DN20)	R3/4in(DN20)	R3/4in(DN20)	R3/4in(DN20)	R3/4in(DN20)	R3/4in(DN20)
Stuffing Quantity	20/40/40H	unit	320/656/732	320/656/732	320/656/732	240/496/558	240/496/558	129/264/307

		60Hz						
Model	Indoor		TVWMH(2.2)2R1	TVWMH(2.8)2R1	TVWMH(3.6)2R1	TVWMH(4.5)2R1	TVWMH(5.6)2R1	TVWMH(7.1)2R1
Capacity	Cooling	kW	2.2	2.8	3.6	4.5	5.6	7.1
	Heating	kW	2.5	3.0	4.3	5.0	6.0	8.0
Electric Data	Power Supply	V~,Hz,Ph	208~230,60,1	208~230,60,1	208~230,60,1	208~230,60,1	208~230,60,1	208~230,60,1
	Rated Power	W	60	60	60	80	80	137
Performance	Air Flow Volume(Hi/Mid/Low)	m ³ /h	620/496/434	620/496/434	620/496/434	950/760/665	950/760/665	1100/880/770
	Noise Level(Hi/Mid/Low)	dB(A)	38/35/31	38/35/31	38/35/31	41/38/34	41/38/34	45/42/37
Dimension(WxDxH)	Net	mm	880x286x203	880x286x203	880x286x203	1095x312x215	1095x312x215	1310x322x240
	Packing	mm	950x350x270	950x350x270	950x350x270	1175x375x275	1175x375x275	1420x440x380
Weight	Net	kg	12	12	12	14	14	20
	Gross	kg	14	14	14	17	17	23
Refrigerant Type			R410a	R410a	R410a	R410a	R410a	R410a
Pipe Diameter	Liquid Side	mm	6.35	6.35	6.35	6.35	6.35	9.52
	Gas Side	mm	9.52	9.52	9.52	12.7	12.7	5.88
	Drainage	mm	R3/4in(DN20)	R3/4in(DN20)	R3/4in(DN20)	R3/4in(DN20)	R3/4in(DN20)	R3/4in(DN20)
Stuffing Quantity	20/40/40H	unit	320/656/732	320/656/732	320/656/732	240/496/558	240/496/558	129/264/307

★ Remark: The above designs and specifications are subject to change of product improvement without prior notice.

Create an exquisite interior complemented by elegant design and quiet performance

The slim, elegant TOYO Console Type indoor unit is designed to perfectly fit spaces with high ceilings and numerous windows while maintaining an optimal indoor temperature. TOYO's console air conditioning solution makes any environment more pleasant and comfortable with features such as:

Two-way airflow

Featuring a 2-way air outlet, console unit includes two separate air outlets for cooling and heating. The warmer air comes out from the bottom part of the air outlet to spread the warm air evenly throughout the room. Users stay cooler or warmer in every corner of the room.



Quiet comfort

This powerful, efficient cooling and heating system makes the room more comfortable than ever before with quiet operation of only 23 dB. Users can select from four different operating modes: high, medium, low and silent (applicable to CAC only).

Slim, low-profile design

console type air conditioner is only 199 mm thick, the slimmest on the market, and its unobtrusive design easily integrates into any décor.

Stay-clean panel

The intelligently designed clean panel keeps dust from accumulating, so the unit and the room stay cleaner.

Sophisticated control

The touchscreen display delivers convenient control, and is an elegant example of functional art.



Distribute refreshing airflow where needed with a compact, flexible design

The Ceiling Type indoor unit has 2-way installation options for the ceiling and floor, enabling more efficient use of available space. Users can enjoy crisp, powerful air throughout their entire space from the compact unit in the ceiling or floor.

Small package, big performance

The Ceiling Type air conditioner boasts a slim, compact design—half the size of conventional products—with cooling power comparable to larger units.

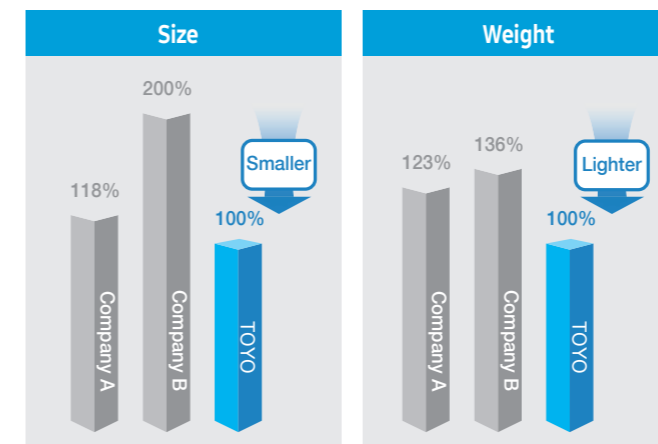

7.1kW Model

Choice of installation options

Depending on the available space and the purpose of the air conditioner, the indoor unit can be installed behind the ceiling the ceiling or on the floor.



Combine simple neat and innovated technologies to experience superior performance and easy operation

Toyo-ac has been rewriting product descriptions beyond the industry standards. As one of such company's product, TOYO Ceiling focused on sending "sufficient" amount of conditioned air to "distant" places to cover huge area. For convenient installations and maintenances, the Ceiling concentrated service direction on one side. Do not get stressed with air conditioning. Just leave it to TOYO Ceiling.

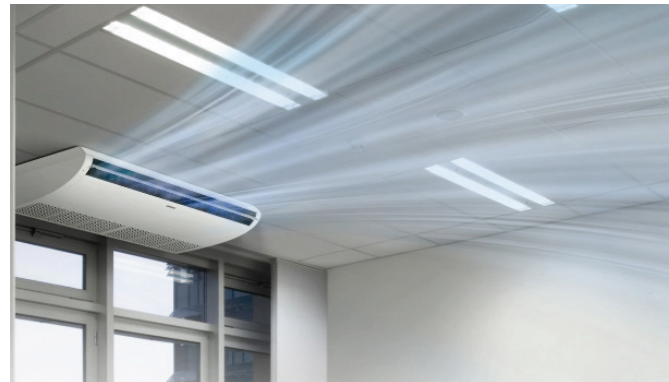

Fast cooling, 15m air flow

When users need air conditioning, they really need it quickly. While the ceiling applied latest flow-efficient blowers to increase amount of air it discharges, it also mounted single motor to reduce noises and possibilities of abrupt changes of modes. With increased size of inlet area and fluid dynamically designed inner passages, customers can experience incomparable cooling power.

Also, with the advanced blade, which can move from 4° to 45°, TOYO ceiling type can refreshingly cool air that reaches every corner of the room with no blind spots.

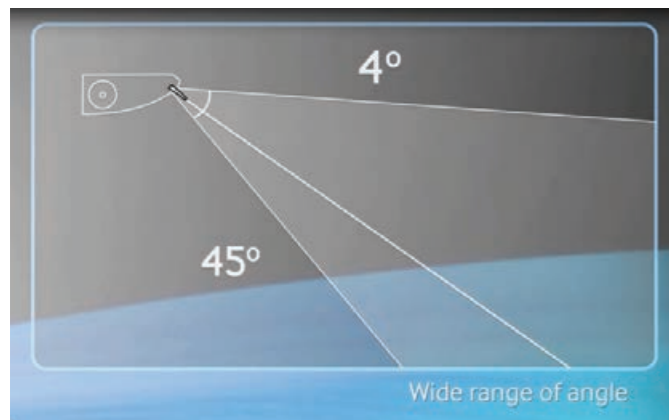

Simple display

The simple display design with its rounded corners adds a neat and tidy feeling to your interior



- Ice Blue : Operating
 - Yellow Green : Schedule
 - Red : Error
 - Orange : Filter Alarm
- Time Limit + Operating Pattern

Cleaner, healthier air

Users can sanitize indoor air with the optional Virus Doctor for a cleaner work or living environment. The easy-to-install Virus Doctor generates active hydrogen and oxygen ions to eliminate airborne contaminants, completely eradicate airborne bacteria and allergens, and even neutralize OH (hydroxyl) radicals.

Comfortable airflow control

The purpose of air conditioners is to provide a pleasant indoor environment for users. To better serve this purpose, TOYO 4Way Cassette S provides a Comfort Airflow Control function that prevents cold drafts. When the room temperature reaches 23°C during cooling mode, the indoor unit reduces the amount of discharging air. By doing so, people in the room avoid the discomfort of direct contact with cold airflow.

Specification-50Hz AC fan motor

Model	Indoor		TVCFH(4.5)4R1	TVCFH(5.6)4R1	TVCFH(7.1)4R1	TVCFH(8)4R1
Capacity	Cooling/Heating	kW	4.5	5.6	7.1	8.0
		kW	5.0	6.0	8.0	10.0
Electric Data	Power Supply	V~,Hz,Ph	220~240,50,1	220~240,50,1	220~240,50,1	220~240,50,1
		Cooling/Heating Power Input	W	80	80	140
Performance	Air Flow Volume(Hi/Mid/Low)	m³/h	950/760/665	950/760/665	1300/1040/910	1500/1200/1050
		Sound Power Noise Level	dB(A)	42/39/36	42/39/36	45/42/39
Dimension (W×D×H)	Net	mm	929×660×205	929×660×205	1280×660×205	1280×660×205
		Packing	mm	1010×720×290	1010×720×290	1360×720×290
Weight	Net/Gross	kg	26/29	26/29	35/39	35/39
		Liquid Side	mm(inch)	6.35(1/4)	6.35(1/4)	9.52(3/8)
Pipe Diameter	Gas Side	mm(inch)	12.7(1/2)	12.7(1/2)	15.88(5/8)	15.88(5/8)
		Drainage	mm(inch)	DN20(R3/4)	DN20(R3/4)	DN20(R3/4)
Stuffing Quantity	20/40/40H	unit	136/280/315	136/280/315	96/200/225	96/200/225

Specification-50Hz AC fan motor

Model	Indoor		TVCFH(9)4R1	TVCFH(10)4R1	TVCFH(11.2)4R1	TVCFH(12.5)4R1	TVCFH(14)4R1
Capacity	Cooling/Heating	kW	9.0	10.0	11.2	12.5	14.0
		kW	11.0	12.0	12.8	13.3	15.0
Electric Data	Power Supply	V~,Hz,Ph	220~240,50,1	220~240,50,1	220~240,50,1	220~240,50,1	220~240,50,1
		Cooling/Heating Power Input	W	140	140	210	210
Performance	Air Flow Volume(Hi/Mid/Low)	m³/h	1500/1200/1050	1500/1200/1050	1800/1440/1260	1800/1440/1260	1800/1440/1260
		Sound Power Noise Level	dB(A)	47/44/41	47/44/41	48/45/42	48/45/42
Dimension (W×D×H)	Net	mm	1280×660×205	1280×660×205	1631×660×205	1631×660×205	1631×660×205
		Packing	mm	1360×720×290	1360×720×290	1710×720×290	1710×720×290
Weight	Net/Gross	kg	35/39	35/39	45/51	45/51	45/51
		Liquid Side	mm(inch)	9.52(3/8)	9.52(3/8)	9.52(3/8)	9.52(3/8)
Pipe Diameter	Gas Side	mm(inch)	15.88(5/8)	15.88(5/8)	15.88(5/8)	15.88(5/8)	15.88(5/8)
		Drainage	mm(inch)	DN20(R3/4)	DN20(R3/4)	DN20(R3/4)	DN20(R3/4)
Stuffing Quantity	20/40/40H	unit	96/200/225	96/200/225	80/168/189	80/168/189	80/168/189

Notes:

1. Cooling Capacity: Indoor temperature 27°C DB/19°C WB; Outdoor temperature:35°C DB/24°C WB.
2. Heating Capacity: Indoor temperature 20°C DB; Outdoor temperature:7°C DB/6°C WB.
3. Piping Length: Equivalent piping length: 7.5m, level difference: 0m.
4. Floor standing: Sound level is measured 1m from air-outlet in horizontal distance, 1m above the floor in vertical distance.
5. Ceiling mounted: Sound level is measured 1m from air-outlet in horizontal distance, 1m from air-outlet in vertical distance.
6. The above designs and specifications are subject to change without prior notice. Final specifications please refer to technical specification provided by sales representative.

Accommodate individual space requirements with adaptable, silent performance

The Toyo-ac Concealed Floor Standing unit offers the utmost in versatility in solving varied cooling and heating needs. This unit effectively adjusts its performance to meet the needs of the space, such as high ceilings and lots of windows, while maintaining the desired temperature.

High performance for versatile installations

The Concealed Floor Standing unit offers wide versatility in solving cooling and heating space requirements for a variety of environments, such as offices, schools and hotels. Whether on the floor or mounted, the unit compensates for conditions such as high ceilings and windows while delivering consistent cooling and heating performance. When mounted in a window, the unit blocks the air from getting through the gap in the window and maintains the desired indoor temperature.



Silent operation

This silent yet powerful unit, operating at a mere 27 dB, offers an efficient cooling and heating solution that makes spaces more comfortable and carefree than ever before.

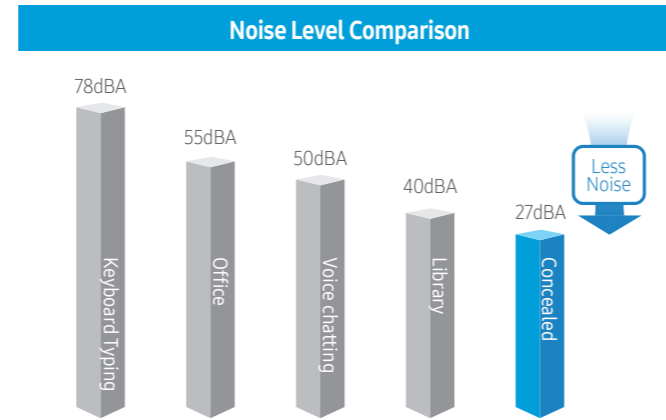

Enjoy high-efficiency ventilation for a more refreshing atmosphere

Indoor air quality is gaining more and more attention as increasingly more people become ill from airborne contaminants. Indoor air contamination is often the cause behind building-related syndromes, such as asthma, headaches and dizziness.

The ERV (Energy Recovery Ventilation) system air conditioner provides fresh, healthy air from outside while minimizing energy loss for maximum efficiency. Its intelligent structure incorporates features specifically designed for low ventilation and efficient operation.

Heat Recovering Method of ERV System

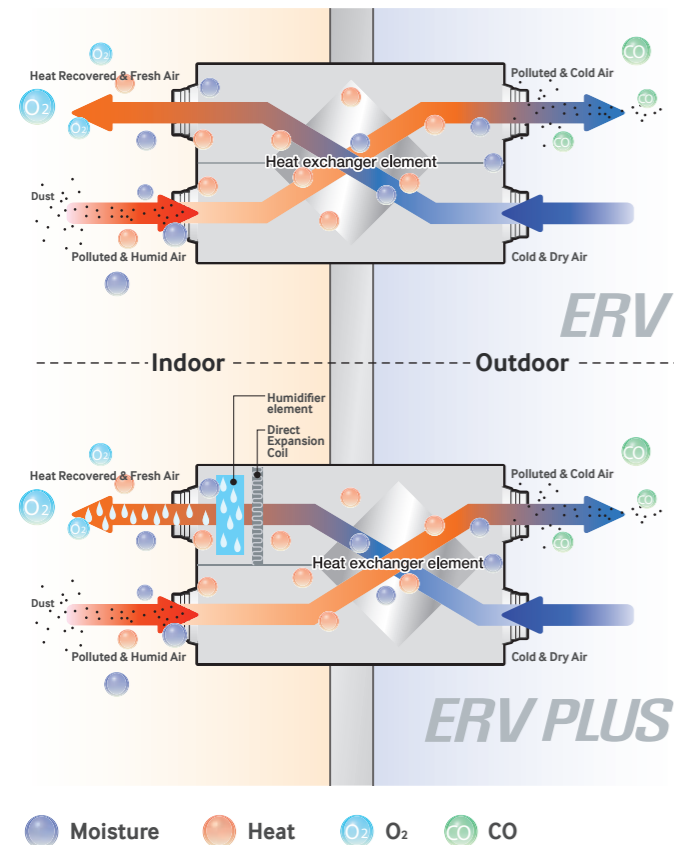

The Toyo-ac ERV and ERV Plus air conditioner systems deliver optimal efficiency, quality and performance with features such as:

- **Superior energy savings.** Lower energy consumption and costs with a direct expansion (DX) coil and advanced heat exchange.
- **Enhanced performance.** Enjoy fresher air, quieter operation and humidity control for a more pleasant environment.
- **Optimized design.** Ease installation and drive higher, more efficient airflow with a slim, compact design.



Drive energy savings with unparalleled heat exchange and automated temperature control

Toyo-ac ERV and ERV Plus deliver exceptional cooling and heating all year round by employing the following heat recovery method:

1. A 2-way ventilation design with air inlets and outlets on both sides of the units provides superior ventilation efficiency.
2. The remaining surface of the heat exchange area transfers heat energy while preventing the discharged contaminants from re-entering.
3. The system recovers up to 70 percent of the energy needed to cool or heat the environment. The efficient heat recovery maintains the indoor temperature and humidity during the winter, and prevents outdoor heat and moisture from entering indoors during the summer.

Auto Mode

ERV and ERV Plus automatically change operation mode, depending on the temperature difference between the indoor and outdoor environment, to conserve energy.

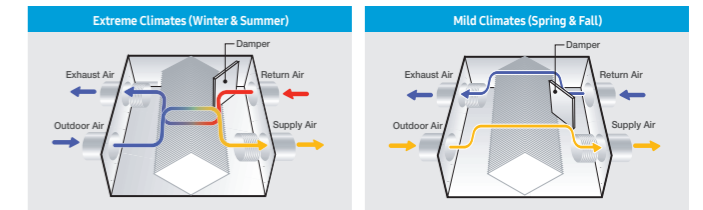

Energy Saving Mode

Toyo-ac ERV systems, coupled with an air conditioner, provide world-class energy-saving solutions to intelligently reduce air conditioner operation hours. Decreased air conditioner operation lessens the cooling and heating load while maintaining optimal performance.

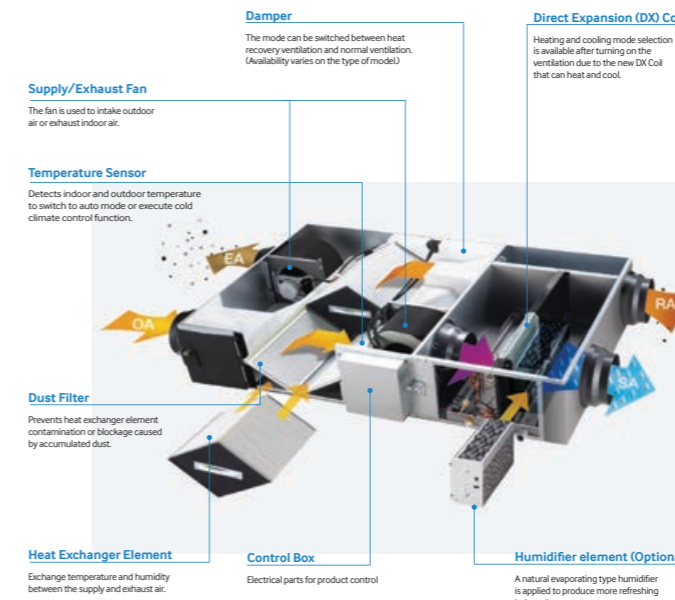
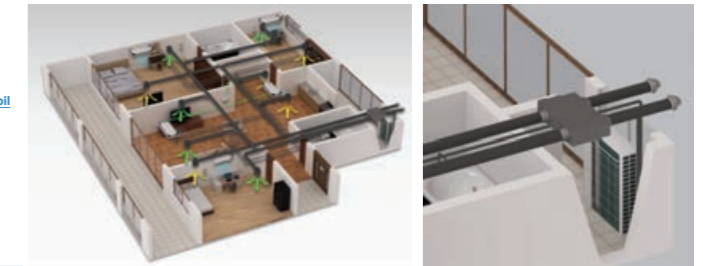

Enhance the indoor environment with ultimate freshness and distraction-free operation

With ERV and ERV Plus systems, users can enjoy high-performance comfort throughout their environment with crisp air quality and low noise levels.

Fresh air without temperature loss

It is equipped with a direct expansion coil to pre-condition the outdoor air that enters the indoor environment. Outdoor air passes through the DX coil to produce fresh air without any temperature loss.

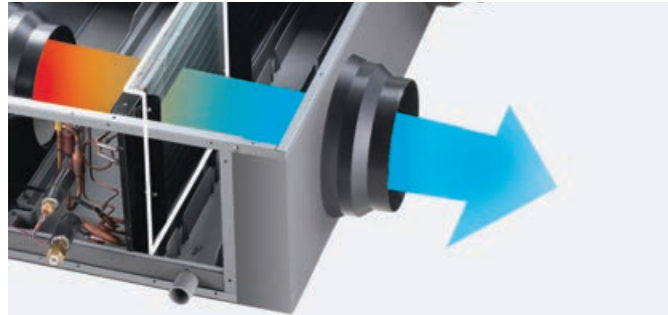

Peaceful performance

units feature Quiet Mode for more discreet operation compared to ordinary ventilators.



Simplify installation and expand airflow with an efficiency-boosting design

offer a smart, efficient design that enables users to deliver fresher air wherever needed with more installation options.

Flexible setup*

The system can be installed vertically or horizontally. This installation flexibility saves time on maintenance when installing more than one unit. Users can reduce the number of service holes

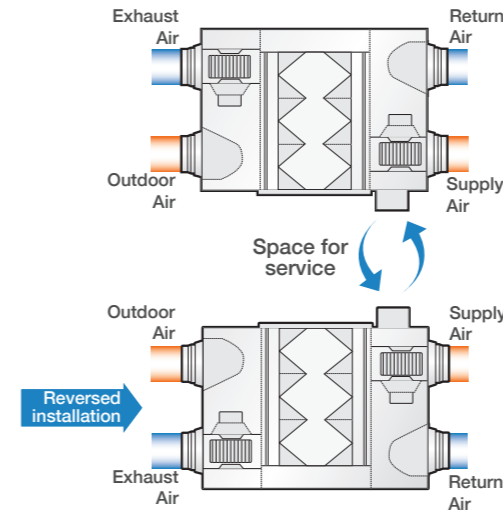

Perfect design for maximum airflow

The new diamond type heat exchanger features an optimized airflow design. This element is compact in size, but offers higher efficiency than conventional rectangular and hexagonal type heat exchangers.

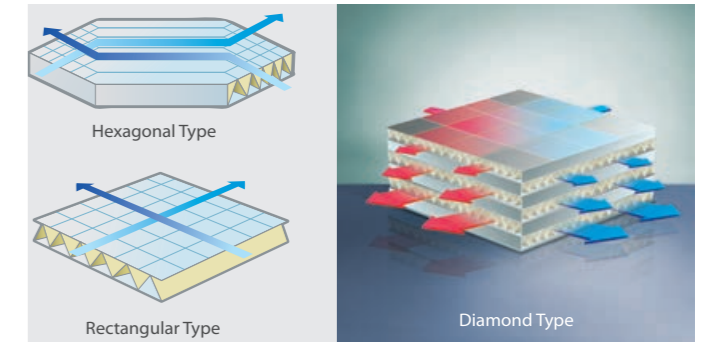

Slim build

Toyo,s advanced technology promotes a slim, compact product. By applying a highly efficient heat exchanger element, has been able to reduce the system's height to 270 mm. Compared to traditional units with rectangular-type heat exchangers units use space more efficiently with their slim, diamond-shaped design.

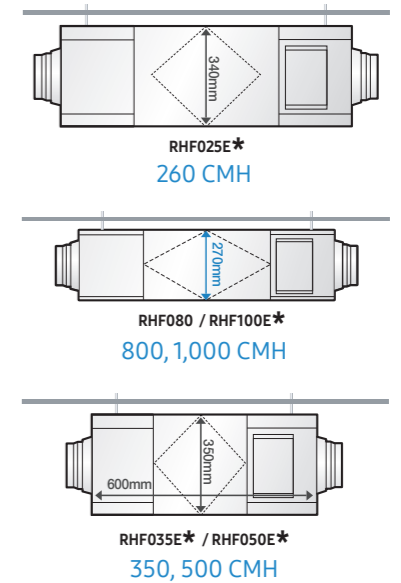

Specification-HRV

Model		THR-200/4	THR-300/4	THR-400/4	THR-500/4	THR-600/4	THR-800/4	THR-1000/4	
Volume	m ³ /h	200	300	400	500	600	800	1000	
	CFM	118	176	235	294	353	471	588	
External static pressure	Pa	75	75	100	110	110	120	120	
Electric Data	Power Supply	V-,Hz,Ph	220-240,50,1	220-240,50,1	220-240,50,1	220-240,50,1	220-240,50,1	220-240,50,1	
	Power Input	W	65	130	200	220	220	410	510
Cooling	Temp. Efficiency	%	62	63	61	60	63	63	
	Enthalpy Efficiency	%	56	56	56	54	55	54	
Heating	Temp. Efficiency	%	72	71.5	71	70	72	71	
	Enthalpy Efficiency	%	58	56	56	56	62	62	
Noise Level	dB(A)	34	34.8	36	36	37.5	38.5	41.5	
Net Dimension(WxDxH)	mm	660x580x264	744x599x270	744x804x270	828x904x264	824x904x270	1116x884x388	1116x1134x388	
Flange	mm	ϕ 144	ϕ 144	ϕ 144	ϕ 194	ϕ 194	ϕ 243	ϕ 243	
Net Weight	kg	23	27	33	46	48	63	79	
Stuffing Quantity	20/40/40H	unit	280/568/710	216/456/513	168/344/387	112/244/280	112/224/252	72/156/156	60/120/120

Specification-HRV

Model		THR-1500/5	THR-2000/5	THR-2500/5	THR-3000/5	THR-4000/5	THR-5000/5	
Volume	m ³ /h	1500	2000	2500	3000	4000	5000	
	CFM	882	1176	1471	1765	2353	2941	
External static pressure	Pa	160	170	180	200	220	240	
Electric Data	Power Supply	V-,Hz,Ph	380-415,50,3	380-415,50,3	380-415,50,3	380-415,50,3	380-415,50,3	
	Power Input	W	1000	1200	2000	2100	2400	3000
Cooling	Temp. Efficiency	%	62	60	62	64	64	64
	Enthalpy Efficiency	%	51	52	50	55	51	55
Heating	Temp. Efficiency	%	70.5	70	70	72	71	72
	Enthalpy Efficiency	%	62	63	63	64	64	65
Noise Level	dB(A)	51	53	55	57	64	64	
Net Dimension(WxDxH)	mm	1500×1200×540	1500×1200×540	1500×1200×540	1500×1200×540	1620×1330×990	1620×1330×990	
Flange	mm	320x300	320x300	320x300	320x300	323x253	500x690	
Net Weight	kg	173	186	200	270	300	320	
Stuffing Quantity	20/40/40H	unit	20/40/40	20/40/40	20/40/40	8/18/18	8/18/18	



Controls

VRV control systems

The VRV controls system provides an advanced architecture that ensures optimum comfort and building management.

